

CK701 - 1W Power Amplifier

This is a 1 watt mono amplifier module Kit using the TDA 7052 from Philips. It is designed to be used as a building block in other projects where a battery powered audio amplifier is required to drive a small speaker. It will operate best from 6 – 12 V DC and requires no heatsink for normal use. Two may be used for stereo applications.

- The kit has a low component count
- No external heatsink is necessary
- It is short circuit protected
- Ideal for 3V - 12V battery operation into an 8 ohm speaker
- Use with Kit 98 if more gain is required

Assembly Instructions :

Assembly is very straight forward. Make sure you get the integrated circuit and the electrolytic capacitors the correct way around. The electrolytic capacitors are polarized, they have a + or - marked on them and they must be inserted correctly into the PCB. The IC and socket have a notch at one end, which is marked on the PCB board overlay. Solder the socket in place first before installing the IC itself. Leave the potentiometer until last. If you require fixed gain, you may leave off the spindle.

Check the polarity before connecting the battery or power supply. If it does not work, recheck all component positions and polarity. Check all solder joints, and all external wiring. The IC itself is quite robust, and there is very little else to go wrong.

Remember when testing, it will not produce full output for more than a short duration because of limited heat dissipation. (This will not be a problem for music applications). It will not produce full output with a 4 ohm speaker because of output current limitations, or with DC input less than 6V.

Circuit Description :

There are only 5 external components. C1 is the input coupling capacitor, which blocks any DC that might be present on the input. C2 and C3 provide power supply decoupling, and R2 provides adjustable input level. This can be used as a volume control.

The Phillips data sheet contains all the necessary information about the TDA7052. You may download it from the software download page on our website at :

<http://www.ElectronicKits.com>

Specifications :

D.C. input : 3 – 15 V at < 300 mA.
Idle current < 8 mA, 4 mA typical.
Power output > 1 Watt @ 8 ohms maximum.
> 0.25 Watt RMS continuous
Freq. Resp. > 20 Hz – 20 kHz
~ 10 – 50 kHz, – 3dB
THD < 1 % @ 100 mW, 0.2% Typ.
S/N ratio > 70 dBA
Gain ~ 30 dB maximum.
Input Z ~ 10 k ohm.

Components :

C1 : 2.2uF electrolytic capacitor	1
C2 : 100nF ceramic/mono	1
C3 : 100uF electrolytic	1
R1 : 1K ohm resistor	1
R2 : 10K ohm log potentiometer	1
Spindle for potentiometer	1
TDA7052 Integrated Circuit	1
8 pin IC socket	1
Kit 27 Printed Circuit Board	1

CK701 - 1W Power Amplifier

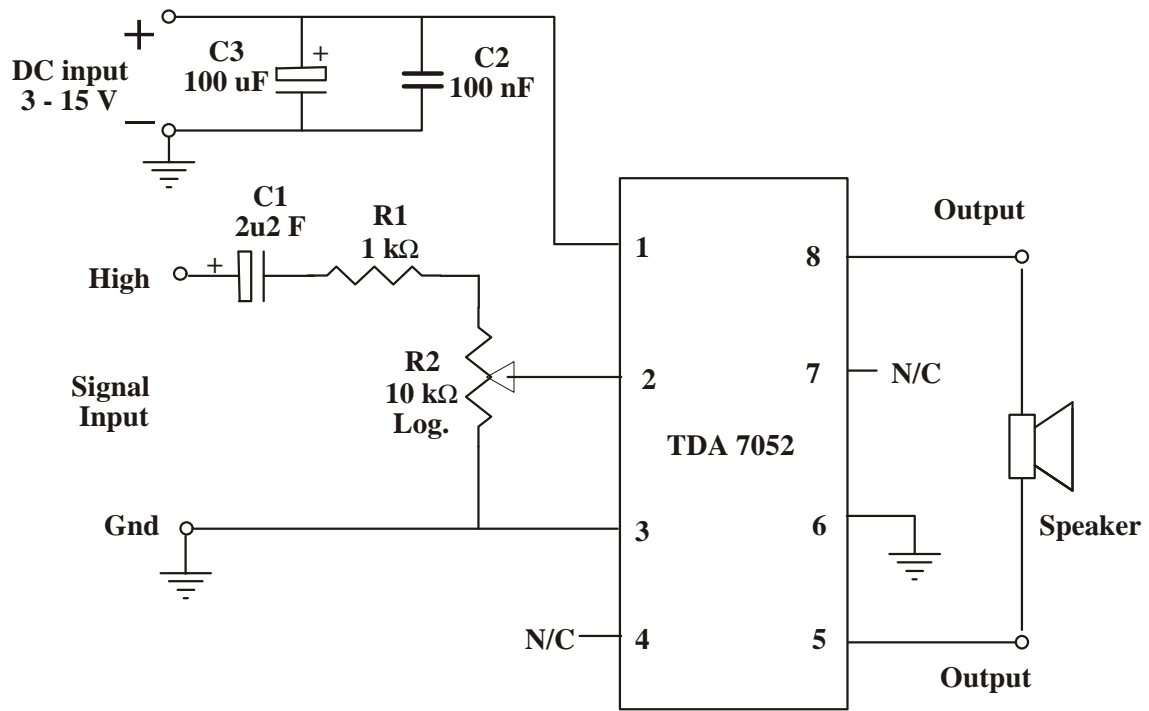

Note ! Do not ground either speaker terminal.

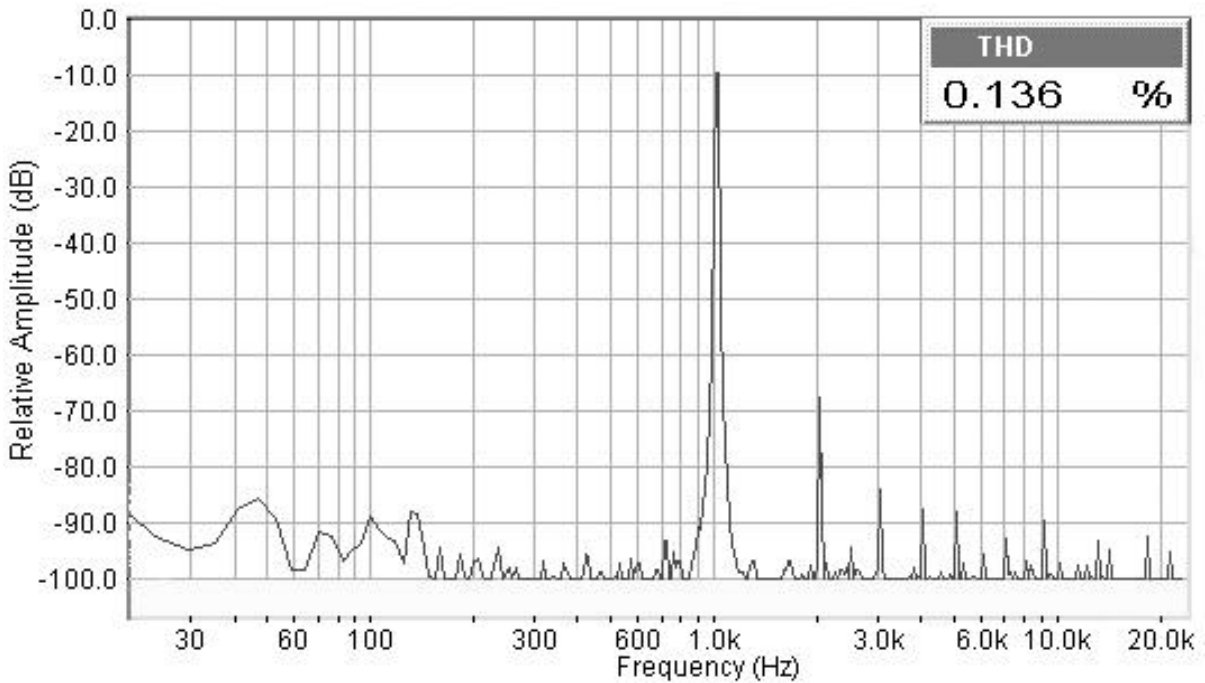

Harmonic Distortion at 1 kHz.
100 mW into 8 ohms.
12V DC input from battery.

CK701 - 1W Power Amplifier

