

CK1605 THREE TIMER KITS

This single documentation covers **three timer kits**: K85_1, K85_2 and K85_3. These kits may be sold separately or all together.

Timer kits are an ever popular item with the hobbyist. Two of the main methods used are a 555 IC and the discharging of an electrolytic capacitor. In this Kit we have presented three representative samples of these types of timers.

There is nothing original in these circuits.

Similar circuits have been presented in text books and electronics magazines for literally decades. The 555 had its own cult following back in the 1970's after it came out.

Whole books of circuit designs were published using it. In the 1990's it has become a favorite chip for some people to look down on (see Don Lancasters comments about it in his columns in the American electronics magazines.)

But despite this it is simple to use and popular because it is so cheap and readily available.

We have placed similar input & output circuits on each of these 3 kits so the essential differences between the designs are more apparent. Input protection diodes are connected in series with the positive supply to prevent any current flow in the circuits if the power supply is connected the wrong way around. The usual diode is placed around the relay to damp the back emf from the relays coil. There is ample opportunity to experiment with these circuits to change them to suit your particular purpose. In particular we explore the 555 chip and show how it can be used quite simply to create very long duration timers.

These kits are constructed on a single-sided, routed, FR4 fibre glass printed circuit board (PCB) with a printed overlay and bottom solder mask. Protel Autotrax and Schematic were used to produce them.

ASSEMBLY INSTRUCTIONS

There are three separate kits here each with their own PCB and components: kit 85_1, kit 85_2 and kit 85_3. We suggest you build and experiment with one kit at a time. Check off the components against the Component listing. It is generally easiest to solder the lowest height components first - the resistors, diodes and IC sockets. There is one link to add on k85_1. Make sure you get the diodes and electrolytic capacitors around the correct way according to the overlay. Pay attention to the orientation of the hatkey switches in kits 85_2 & 85_3. Make sure the flat on the switch corresponds to the flat shown on the overlay.

In kit 82_2, three insertion sockets have been supplied so you can experiment with using different values of electrolytic capacitors. Solder these into the 3 pads at C1. Later you can replace them with a single capacitor. An extra electrolytic capacitors has been provided in this kit for experimentation as described below.

CIRCUIT DESCRIPTION

555 Differences. First a general comment about the 555 IC. It is generally stated in the text books and assumed in the magazine articles about it that all 555's are the same. And

in many applications they are. But in many other applications they definitely are not, especially when you are designing near the specification limits of the IC. On top of this we have also found that there are differences between the same type of 555 (whether nmos, or the lower power cmos version) made by different manufacturers. These problems must be kept in mind when you design using the 555. You must always prototype & test exhaustively and do not change IC brands nor nmos/CMOS types without comprehensive testing. These comments also apply to the 556 IC (two 555 in the same package.) This problem of differences has not been widely reported although it is frequently alluded to in recent electronics magazine articles. (One senses the frustration reviewers have had when using different brands of 555.)

We have not attempted to review the operation of the 555 IC here. Most electronic magazines review it in detail once every few years. And it is a standard feature in most introductory electronic text books. Some magazine references are given at the end of this documentation.

Kit 1605_1. The circuit consists of 3 parts: an oscillator, a ripple counter and a switching transistor. The 555 is configured in the standard astable oscillator circuit designed to give a square wave oscillation at a period of around 1 cycle/sec. A potentiometer is included in the design so the period can be set to exactly 1 second by timing the LED turning on/off. A separate jumper connection has been provided so the LED can be turned off completely if it is not required. The output pulse is fed to a 14-stage binary ripple counter.

The 14020 ripple counter advances its count on each negative transition of the clock pulse from the 555. So for each output cycle of low-high-low-high the count is advanced by two. It can be set to an zero state (all outputs low) by a logic high applied to pin 11. In this circuit C3, R4 and D1 are arranged as a power-on reset. When power is applied to the circuit C3 is in a discharged state so pin 11 will be pulled high. C3 will quickly charge via R4 and the level at pin 11 falls thus enabling the counter. The 14020 then counts clock pulses until the selected counter output goes high. This output turns Q1 on which in turn activates the relay. Note that the reset pin of the 555 is connected to the collector of Q1. This enables the 555 during the counting period but as soon as Q1 is turned on the 555 is disabled as the collector of Q1 is pulled low.

The counter output required is set by a jumper. Eleven outputs are available: 8 16 32 64 128 256 512 1024 4096 and 8192. If the 555 is set to oscillate at exactly 1.0Hz by the on-board trimpot then the maximum timer interval which can be set is 8192 seconds. You can experiment with changing the components values of R1 and C1 to set the frequency at 10 seconds or a minute so timing periods of 81,920 seconds & 491,520 second can be reached easily. (You can work out how many days & hours this is.)

The relay will remain activated until the power is turned off at the switch by the user. D1 provides a discharge path for C3 once the power is disconnected.

CK1605 THREE TIMER KITS

Kit 1605_2. In the previous kit the period of oscillation of the 555 was set to 1 second. And we suggested that with a change of component values that 10 seconds or even a minute was possible with a consequent increase in the maximum timing delay which could be achieved. This raises the question of what is the maximum period that the 555 can be set to as an astable oscillator. This kit explores the limits of the 555 as a timer IC.

Kit 1605_2 is the traditional 555 monostable timer circuit. Pin 2 the trigger input is tied high except when the switch pulses it low to start the timer. Pin 4 the reset pin is tied high except when it the switch pulses it low to reset it. The switched output is similar to that already met in kit 85_1.

We have also changed the threshold trigger levels by attaching a voltage divider to pin 5. Normally with pin 5 just left unconnected or connected to ground via a 10nF capacitor the 555 will turn on when pin 2 is taken below 1/3 the supply voltage, and will turn off when pin 6 rises above 2/3 the supply voltage. However, by applying a voltage to this pin the comparator reference levels may be shifted either higher or lower than the nominal 1/3, 2/3 levels. We have applied about 10.8V to pin 5 in order to raise the turn off threshold higher than the usual 2/3 Vcc.

Check that the three insertion sockets have been placed in the 3 pads at C1. First push in the 100uF electrolytic capacitor. Make sure the positive lead is in the right-most socket. Set the potentiometer to mid range and press start. The LED should go on and the relay should close. Try pressing reset. The LED should go off and the relay should be released. Experiment with the potentiometer in the maximum & minimum positions and see what timing period are obtained. Then try the low leakage 470uF capacitor. What delays do you get now?

Kit 1605_3. As in the previous kit the relay is activated immediately the switch is pressed. Then after a period of time (about 2 to 400 seconds with the component values supplied with the kit) the relay times out. This has application anywhere that a brief pulse is required to turn on a device for anywhere from 2 seconds to about 6 minutes. For example, a night light, delay to leave a room before an alarm is turned on, photographic timer. However, in this circuit we do not use an IC to do the timing. We use the discharge of an electrolytic capacitor.

Normally the relay is off. This is because Q1 is turned off by the potentiometer resistance and R2. Q1 controls Q2. And Q2 controls the relay. All three are normally off. When the switch is pressed two things happen. First the base of Q1 is connected to the +12V supply via R3. Q1 turns on. Resistor R3 limits the amount of current which can flow into the base. Q1 turns on Q3 which in turn activates the relay. The LED turns on to show that the relay is activated. The normally connected output of +12V drops to zero.

The second thing to happen when the switch is pressed is that current also flows into capacitor C1 and charges it. So

when the switch is released the charge in the capacitor keeps Q1 turned on until the charge has decayed away through R2 and the potentiometer. (There is also a small leakage through the transistor due to the base current of Q1.) You can easily increase the time for the charge to decay by increasing the resistance of the potentiometer. If you want longer times you can experiment with a 1mF capacitor or higher.

Mains Switching. These on-board relays on these kits should not be used to switch the mains power directly even though they are rated to do it. To control mains power use our Kit 84 as an interface between the timer kit and the mains power supply. Kit 84 is designed to take a zero to 12V signal, or a 12V to zero signal and switch the mains power on or off.

Long Duration Timers. Combining the 20 minute period for the 555 demonstrated in k1605_2 with the ripple counter of k1605_1 shows that timing periods of 8192*20 minutes (about 110 days) are possible. In this case plug power pack operation would be required. Batteries would be quite unreliable. But accuracy could be a problem since the electrolyte capacitor could not be relied upon to maintain constant internal electrolytic characteristics over this duration. It would be operating at the limits of its specifications.

But there is another way to get a long duration timer, with more accuracy, and without pushing the limits of any of the components. We could just add a second ripple counter to the circuit of kit 1605_1. A 555 oscillating with a period of 1 second and two ripple counters in series set to the maximum of 8192 pulses each, then a timing period of 8192*8192 seconds is possible. This is just over two years. The timing period can be set quite accurately. And we would be operating well inside the specifications for electrolytic capacitors. Setting the period to 10 Hz would give a timing period of over 21 years. Long enough for most purposes we think.

What to do if they do not work. Poor soldering is the most likely reason that any of the kits do not work. Check all solder joints carefully under a good light. Next check that all components are in their correct position on the PCB especially the diodes. Are the IC's in the correct way around. Did you put the link in kit 1605_1.

References:

1. Design Your Own Circuits: Timers. *Everyday Electronics*, May, 1991.
2. Timer Circuits, *Electronics Australia*, May, 1992.
3. The 555 Timer IC. *Electronics Australia*, May & June, 1996.

CK1605 THREE TIMER KITS

Components Kit 1605_1

390K R1 orange white yellow	1
470K R2 yellow violet yellow	1
1K R3 brown black red	1
39K R5 orange white orange	1
100K R4 brown black yellow	1
100K 104 Koa trimpot	1
Capacitors:	
1uF E. cap C1 C3	2
470uF E. cap C5	1
10nF mylar C2	1
100nF 104 monoblok C4	1
NE/LM555 nmos IC	1
8 pin IC socket	1
14020 IC	1
16 pin IC socket	1
BC338 Q1	1
5mm LED	1
1N4004 diode D1 D2 D3	3
2 pole header strip - 1 position	1
2 pole header strip - 4 position	1
2 pole header strip - 7 position	1
Jumper	2
3 pole terminal block	1
2 pole terminal block	1
Relay	1
SPDT switch	1
Kit 85_1 PCB	1

Components Kit 1605_3

220R R1 red red brown	1
1K R5 brown black red	1
2K2 R2 red red red	1
10K R3 R4 brown black orange	2
470uF E.cap C1	1
Piher 200K trimpot	1
BC548 transistor	2
5mm LED	1
1N4004 D1 D2	2
Relay	1
Hatkey switch	1
2 pole terminal block	2
Kit 85_3 PCB	1

See our website at <http://www.electronickits.com> to see our full range of kits.

Components Kit 1605_2

Resistors 1/4W, 5%:	
1K R5 R6 brown black red	2
4K7 R4 yellow violet red	1
10K R7 brown black orange	1
22K R1 R2 red red orange	2
47K R3 yellow violet orange	1
Piher 2M5 trimpot	1
470uF/16V LL E. cap C1	1
470uF/16V E. cap C2	1
100uF E. cap C1	1
100nF 104 monoblok C3	1
Hatkey switch	2
Insertion sockets	3
NE/LM555 nmos IC	1
8 pin IC socket	1
BC547 transistor	1
3mm LED	1
2 pole terminal block	1
3 pole terminal block	1
Relay	1
1N4004 diode D1 D2	2
Kit 85_2 PCB	1

CK1605 THREE TIMER KITS

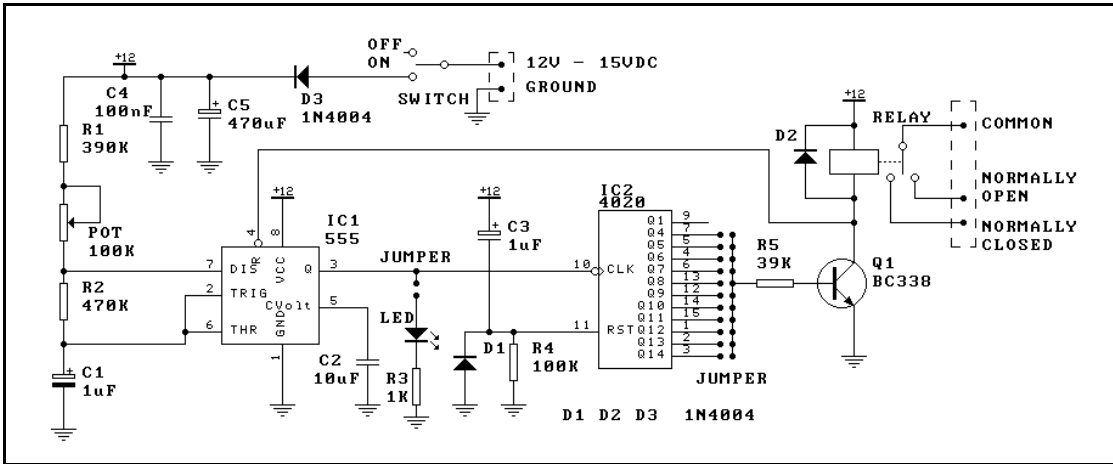

Kit 1605_1

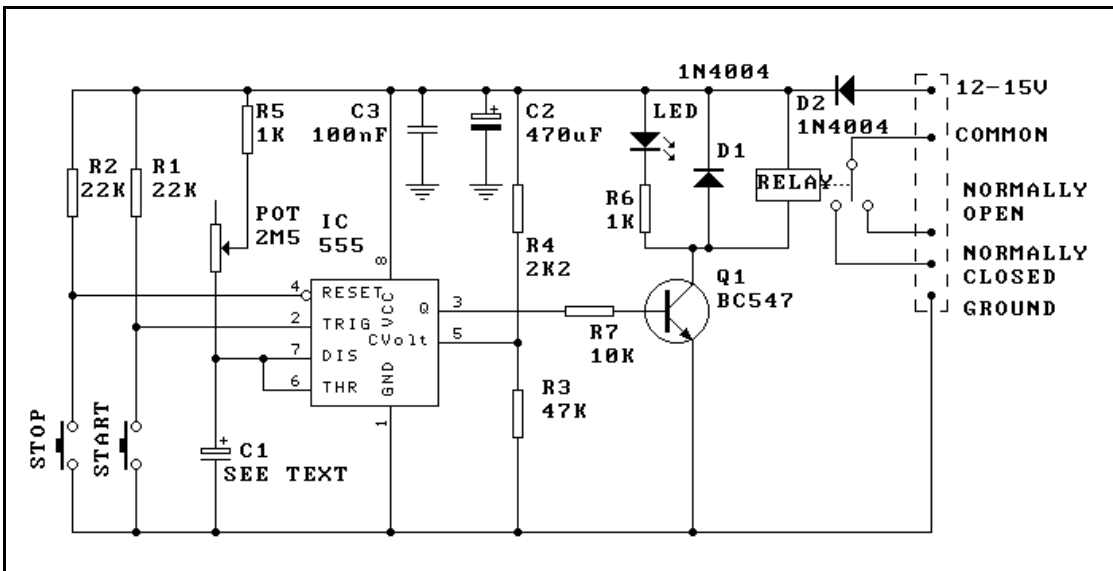

Kit 1605_2

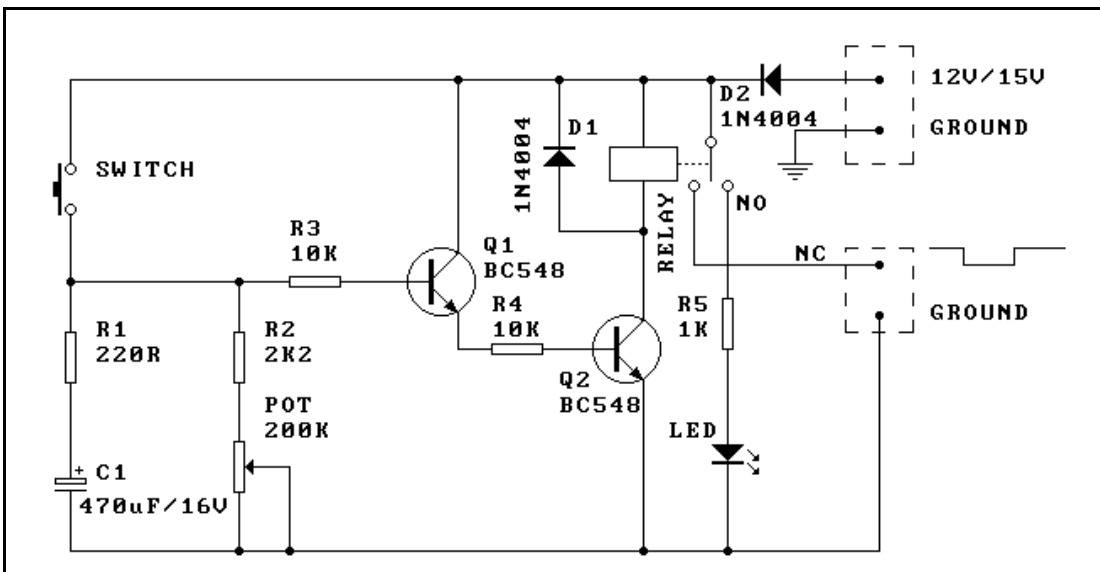

Kit 1605_3