

CK1608 - EIGHT x THREE CHANNEL IR REMOTE CONTROL

This is completely new documentation for this kit written 9/2002. This is because the manufacturer of the match ICs used in this kit has changed the pin numbers of two pairs of pins. So we used the opportunity to upgrade the documents completely. These changes affect the Receiver Board operation and will be described below. (Details of the actual changes are given at the end of the documentation.)

This kit is designed to activate 1 of 8 relays by Infra Red (IR) remote control. A matched pair of IC's especially designed for the purpose is used. Eight buttons on the transmitter unit encode a unique pulse stream modulated at 38 kHz and transmitted by 2 IR LED's. This pulse stream is detected and decoded by the receiver and the appropriate relay on the board is activated. Six of the relays are turned on only when the corresponding button on the transmitter is depressed. The other two relays (relays 7 & 8) toggle on/off with each keypress. Three ranges of operation are built-in. They are activated by jumpers on each board.

The printed circuit boards for the transmitter and receiver are double-sided, plated-through boards. A case is supplied for the transmitter. Protel Autotrax & Schematic were used to design the boards.

Transmitter

IR Emitting Diodes. These are the latest, high power IR LED's from Waitrony, IE-0530HP.

SM5021B Encoder IC. This cmos remote control encoder chip operates on a wide voltage range of 2.5V to 6V. It encodes 8 data keys and there are 4 possible ranges, selected by jumpers. The chip drives the IR LED's at a 38kHz modulated output. A standard 455 kHz ceramic resonator attached across the pins of the IC sets the frequency.

Supertronic Box. The transmitter PCB is designed to fit into this TT5 box from Supertronic'c in Spain. Some drilling of the box has to be done as described below.

Receiver

IR Decoder IC. The PIC-1018SCLS Remote Control Decoder IC from Waitrony is designed to detect, amplify and output the inverse envelope of the 38 kHz IR pulse train it detects in its lens bubble. A transistor switch restores the envelope before feeding it into the decoder IC.

SM5032C Decoder IC. This is the pair IC to the Encoder IC. It decodes the pulse train and outputs a signal on the

appropriate relay line. An LED is also attached to each line for visual indication.

ULN2003A. One of a family of IC's which interfaces between low level logic circuitry and power loads. The ULN2003A has series input resistors selected for interfacing directly with 5V TTL or cmos. There are only seven high voltage, high-current darlington array drivers in the IC. We need eight. So an extra transistor driver, Q2, is incorporated on the board.

Power. A power jack, 12V centre positive is provided on the board. On-board 5V voltage regulation is done by a 7805 3 pin regulator.

Relay Output. Three pole terminal blocks are provided at each relay position for the common C, normally connected NC & normally open NO, outputs.

Construction

Receiver Board. Identify the two packets with the components for the receiver board; one packet has the relays in it & the second has the 7805 & power jack. Add the resistors to the board first. Then add the other components in order of increasing height. When you add the 7805 make sure to bend the legs using needle-nosed pliers. Do not just insert the regulator into the holes and push it over with your finger. This can (please believe me) break the plastic case and destroy the IC. Use the nut & bolt to fix it to the PCB. Make sure to get the electrolytic capacitors around the correct way. The IR decoder, IRM1, must have the lens bump facing to the outside of the PCB as shown on the overlay.

Finally solder in the relays. These relays may have 5 or 6 pins. This is the common connection. If there are two pins they are connected together internally.

NOTE: because of changes in the SM5032C IC output pins without any advanced notice to buyers like myself the following relatively small changes now apply.

1. jumpers J1 and J2 are interchanged. This will not affect users which only use one Tx unit with one Rx unit.
2. Relays 7 and 8 are interchanged. So pressing button 7 on the Tx unit will activate relay 8, and pressing button 8 will activate relay 7. If this is a problem you could just cut and interchange the tracks going to pins 9 and 10 of the SM5032C.

Transmitter Board. Before you do any soldering of the board you must drill some holes in the case. Ideally you should have access to a drill press and the necessary jigs, drill bits and holders. Drill guide holes for the 8 hatkey switches have been put in the PCB. You will have to drill a total of nine holes on the top of the case, two holes on the side and four holes on the base.

CK1608 - EIGHT x THREE CHANNEL IR REMOTE CONTROL

Top. Holes must be drilled for the 8 hatkey switches and the 3mm LED, D1. Drill guide holes for the switches have been provided on the PCB. Place the PCB into the lid over the two upright plastic posts. Drill 8 small (30 thou, 0.8mm diameter) holes through the centre hole of each of the hatkey switch positions. Then enlarge them to 9mm (0.35"). Estimate the LED position and drill it.

Side. Leave these two holes until after the completed circuit board is mounted on the stand-offs to get the correct position.

Bottom. Now drop the PCB into the base over the two upright plastic posts. Drill 4, 3mm diameter holes in each corner of the case as indicated by the holes in the corner of the PCB.

Now you can solder components to the board: first solder the resistors, transistors IC socket, jumpers, capacitors and the ceramic resonator. Make sure to get the low leakage capacitor around the correct way. Do not put in D1 LED yet. This will be the last component to add. Second put in the hatkey switches making sure to match the flat on the switch with the overlay flat line. Use the colour combination which you like best.

IR LED. The short lead of the LED is the cathode. The cathode position is marked with a C on the overlay. The cathode also has the biggest electrode area when you look into the LED. Bend the legs on each LED (using needle nosed pliers) so that the bottom of the LED matches the overlay position.

Case Connections. Note the four lugs poking out of the battery compartment. Use a short half inch length of hook-up wire to solder together one pair of lugs. Now look into the battery compartment and see which of the lugs at the opposite end will be negative and which will be positive. Solder the red wire from the positive lug to the +3V pad. And solder the green wire from the -3V to the ground lug.

Standoffs. Four PCB standoffs are supplied, one for each corner. Each consists of two screws, one nut and one brass spacer 1cm in length. First screw on the nut inside the case to a screw poking up from the bottom of the case. Then screw on the brass spacer. This may need patience with needle nosed pliers, or you can try turning the screw from the bottom after loosening the nut a little.

Now place the PCB into the box. This will show you where to drill the holes in the side of the case for the two IR LED's. Drill them. Now place the PCB back into the case. The final component to solder is the 3mm red LED, D1 since it has to sit up about 1 cm above the PCB.

Secure the PCB to the standoffs with the second set of four screws. Screw on the lid with the 3 screws provided in the case. Note that the short screw goes in the battery compartment and must be put in place before you add the batteries. Finally add the batteries. The red LED should light up when any of the eight switches is pressed.

Make sure that with the lid on the operation of each switch is free and that it does not rub on the side of the hole and stick 'on'.

Operation

You should be able to get over 20 meters range in bright sunlight. Relays 1 to 6 are only activated when the switch is pressed down. Relays 7 & 8 toggle on/off with each press of the switch. You can activate more than one relay at a time; press 4 switches down and the four corresponding relays will turn on.

Although the units is only guaranteed to operate by direct line-of-sight you will find that the IR beam can easily jump off reflective walls, ceilings and around corners.

You can select which of the three ranges of operation you want by placing jumpers at J1 & J2 in both boards. The IC pair support a total of 3x8, or 24 combinations.

What To Do If It Does Not Work.

First try to determine which unit is not working. The LED on the transmitter should light up when any switch is pressed. Check that all the components are in the correct positions: the IC's, electrolytic capacitors, LED's. Use a voltmeter to check the power supply to both boards. If you have a CRO check the output envelope from IRM1.

Jumper Positions. The three ranges are obtained by having no jumpers on either board or one-only jumper on both boards in the corresponding positions.

Due to an error by the manufacturer back in 1998 the two jumpers-on option does not work in SM5032 decoder IC.

New SM5032C 9/2002. The manufacturer again changed the specs without warning. Pins 11 and 12, and pins 9 and 10 were interchanged for the new 'C' version. This means that on the receiver board

- J1 and J2 are interchanged, and
- Relay 7 and relay 8 activation are interchanged.

The first change has no real effect particularly if you do not use the jumpers. The second can be fixed if you want to cut and jumper two tracks on the pins 9 and 10 of the SM5032C on the solder side of the board. This is rather easy to do. Otherwise you just know that pins 7 and 8 on the transmitter activate relays 8 and 7 respectively.

Please see our website at

<http://www.electronickits.com>

(Documentation september 30, 2002.)

CK1608 - EIGHT x THREE CHANNEL IR REMOTE CONTROL

Receiver Board - Components

Resistors, 5%, 1/4W:		
1K brown black red	R3 - R11	9
10K brown black orange	R1	1
39K orange grey orange	R2	1
1N4004 diode	D1	1
1nF 102 ceramic	C2	1
100nF mono	C1 C5	2
1uF/50V mini ecap	C4	1
10uF/25V mini ecap	C3	1
Goodsky AZ-SH-112L relay		8
BC548 transistor		2
IR decoder	IRM1	1
3mm red LED		8
SM5032C decoder	IC1	1
ULN-2003A	IC2	1
7805 3-pin regulator	IC3	1
14 pin IC socket		
16 pin IC socket		1
3 pole terminal block		8
2 pin post header J1 J2		2
Jumpers		
Nut & bolt		1 set
2.5mm power jack		1
K72 receiver PCB		1

Transmitter Board - Components

390R orange grey brown	R5 R6	2
1K brown black red	R1 R4	2
4R7 yellow violet gold	R2 R3	2
2 pin post header	J1 J2	2
Jumpers		2
10uF mini LL ecap	C3	1
100pF	C1 C2	2
455kHz ceramic resonator		1
BC548 transistor		4
Red & green hook-up wire		2 x 3"
IR LED, EL-1L7		2
Hatkey switch		8
3mm red LED		1
SM5021B encoder	IC1	1
16 pin IC socket		1
Supertronic PP5 case		1
Standoff set (1 nut, 2 screws, 1cm spacer)		4 sets
K72 transmitter PCB		1

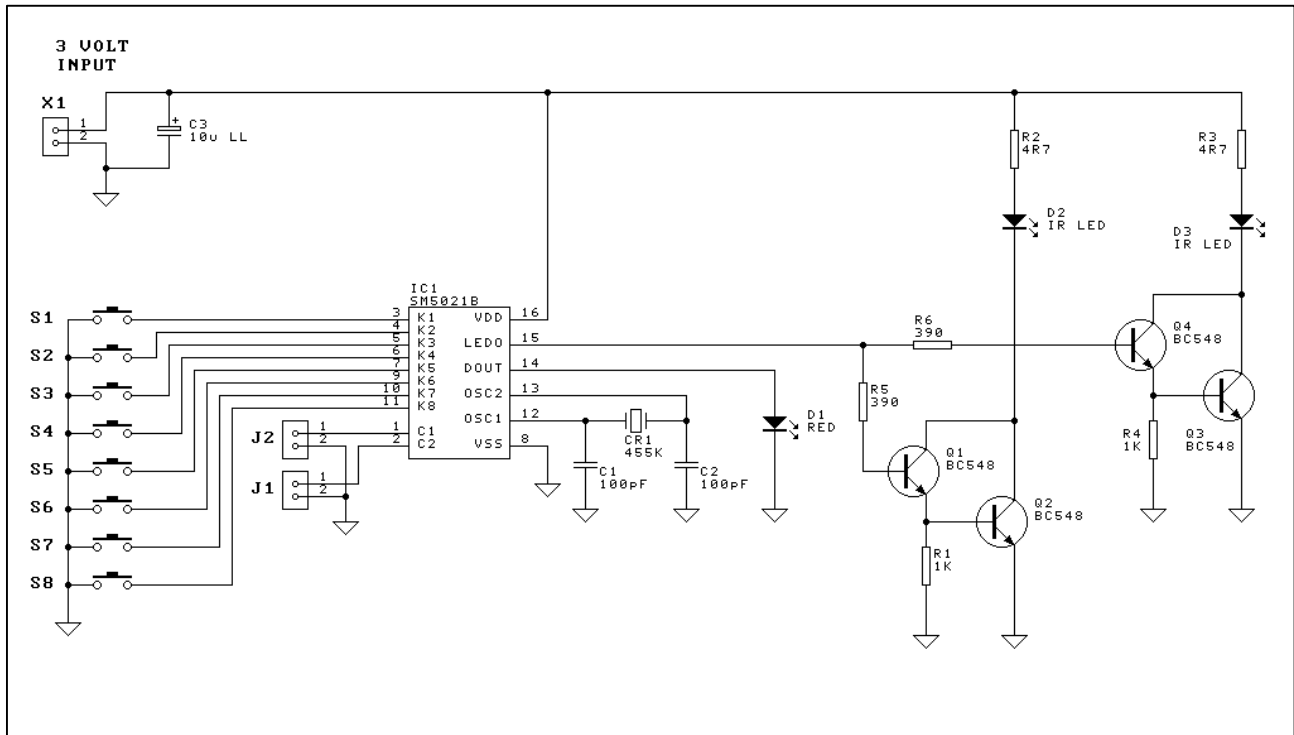

CK1608 - EIGHT x THREE CHANNEL IR REMOTE CONTROL

