

STROBE LIGHT KIT

MODEL AK-520



Assembly and Instruction Manual

PARTS LIST

If any parts are missing or damaged, see instructor or bookstore. **DO NOT** contact your place of purchase as they will not be able to help you.

Contact Elenco Electronics (address/phone/e-mail is at the back of this manual) for additional assistance, if needed.

RESISTORS

Qty	Symbol	Value	Color Code	Part #
□ 1	R1	200Ω 5% 1/4W	red-brown-brown-gold	132000
□ 2	R2, R4	1MΩ 5% 1/4W	brown-black-green-gold	171000
□ 1	R3	2MΩ 5% 1/4W	red-black-green-gold	172000
□ 1	VR1	2MΩ Potentiometer		192731

CAPACITORS

Qty	Symbol	Description	Part #
□ 1	C5	.01μF 10% 200V/250V Mylar (103)	240119
□ 1	C1	.1μF 10% 100V Mylar (2A104K)	251017
□ 1	C6	.1μF 10% 400V Mylar (2G104K)	25102A
□ 1	C3	.22μF 10% 100V Mylar (224)	252217
□ 1	C4	.47μF 10% 250V Mylar (474)	254719
□ 1	C2	470μF 10V Electrolytic (Lytic)	284743

SEMICONDUCTORS

Qty	Symbol	Description	Part #
□ 1	D2	1N4004 Diode	314004
□ 1	D1	1N4148 Diode	314148
□ 1	Q1	2N3904 Transistor	323904
□ 1	SCR	T106D1 / C106D1 SCR	3606D1

MISCELLANEOUS

Qty	Description	Part #	Qty	Description	Part #
□ 1	Transformer (T1)	440002	□ 4	Screw 4 x 1/2" Phillips	642465
□ 1	PC Board	517023	□ 2	Screw 2 x .4 x 5mm Phillips	643148
□ 1	Switch DPDT (SW1)	541107	□ 1	Nut Hex 7mm	644101
□ 1	Neon Bulb (NEON)	585020	□ 1	Nut 2-56 Hex	644201
□ 1	Flash Tube/Trigger Assembly (T2)	586005	□ 1	Flat Washer 8mm	645101
□ 1	Battery Holder	590082	□ 1	Lockwasher 5/16"	646101
□ 1	Bottom Case	62PX2GB	□ 1	Lockwasher #2 INT	646200
□ 1	Knob	622009	□ 1	Tape Double-Sided	740020
□ 1	Top Panel	623107	□ 12"	Wire 22ga. Topcoat Red	814200
□ 1	Screw 2-56 x 5/8" Phillips	641277	□ 1	Solder	9ST4

PARTS IDENTIFICATION

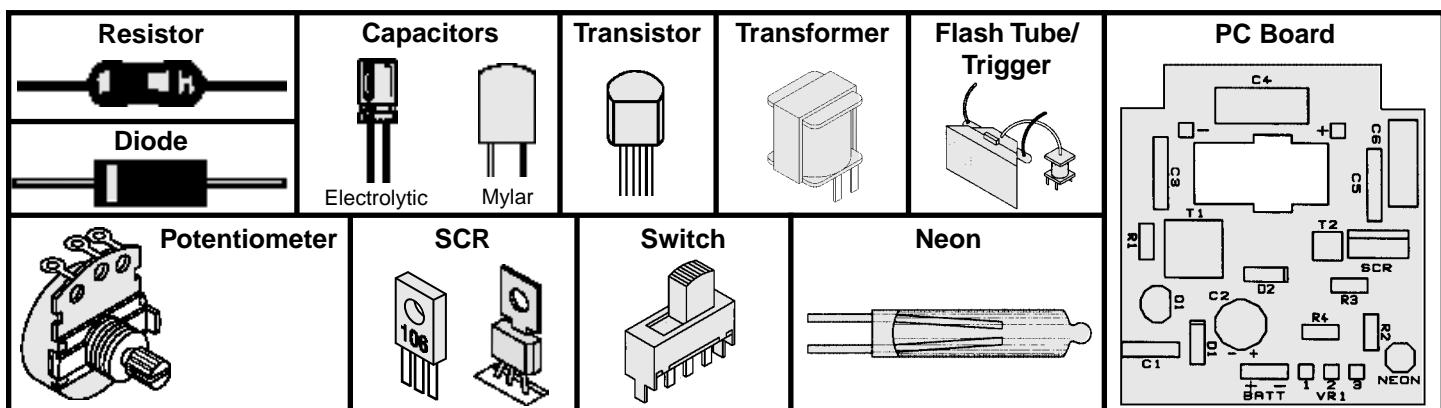

IDENTIFYING RESISTOR VALUES

Use the following information as a guide in properly identifying the value of resistors.

BAND 1 1st Digit		BAND 2 2nd Digit		Multiplier		Resistance Tolerance	
Color	Digit	Color	Digit	Color	Multiplier	Color	Tolerance
Black	0	Black	0	Black	1	Silver	$\pm 10\%$
Brown	1	Brown	1	Brown	10	Gold	$\pm 5\%$
Red	2	Red	2	Red	100	Brown	$\pm 1\%$
Orange	3	Orange	3	Orange	1,000	Red	$\pm 2\%$
Yellow	4	Yellow	4	Yellow	10,000	Orange	$\pm 3\%$
Green	5	Green	5	Green	100,000	Green	$\pm 0.5\%$
Blue	6	Blue	6	Blue	1,000,000	Blue	$\pm 0.25\%$
Violet	7	Violet	7	Silver	0.01	Violet	$\pm 0.1\%$
Gray	8	Gray	8	Gold	0.1		
White	9	White	9				

BANDS

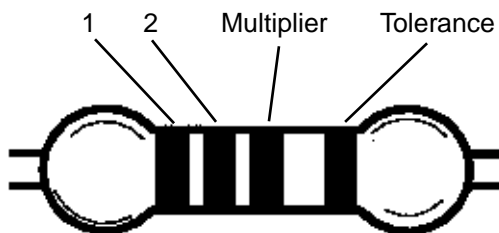

IDENTIFYING CAPACITOR VALUES

Capacitors will be identified by their capacitance value in pF (picofarads), nF (nanofarads), or μF (microfarads). Most capacitors will have their actual value printed on them. Some capacitors may have their value printed in the following manner. The maximum operating voltage may also be printed on the capacitor.

Multiplier	For the No.	0	1	2	3	4	5	8	9
	Multiply By		1	10	100	1k	10k	100k	0.01

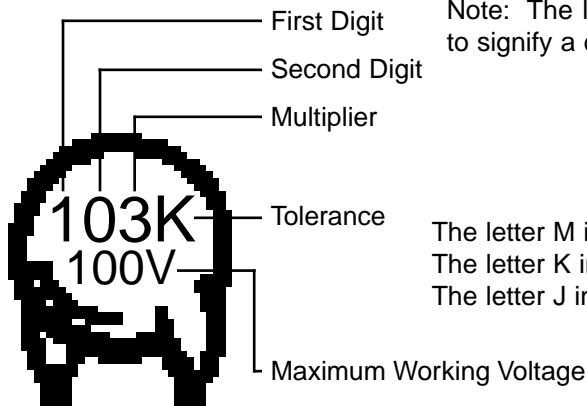
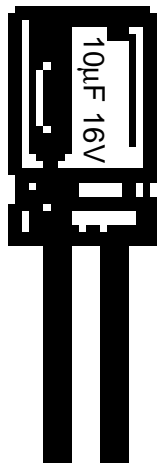

Note: The letter "R" may be used at times to signify a decimal point; as in 3R3 = 3.3

The letter M indicates a tolerance of $\pm 20\%$
 The letter K indicates a tolerance of $\pm 10\%$
 The letter J indicates a tolerance of $\pm 5\%$

The value is $10 \times 1,000 = 10,000\text{pF}$ or $.01\mu\text{F}$ 100V

METRIC UNITS AND CONVERSIONS

Abbreviation	Means	Multiply Unit By	Or
p	Pico	.000000000001	10^{-12}
n	nano	.000000001	10^{-9}
μ	micro	.000001	10^{-6}
m	milli	.001	10^{-3}
-	unit	1	10^0
k	kilo	1,000	10^3
M	mega	1,000,000	10^6

1,000 pico units = 1 nano unit	1,000 nano units = 1 micro unit
1,000 micro units = 1 milli unit	1,000 milli units = 1 unit
1,000 units = 1 kilo unit	1,000 kilo units = 1 kilo unit

INTRODUCTION

Have you ever seen a lightning flash and wonder how the light was produced? This strobe light kit not only explains how a high voltage discharge produces light, but reproduces those bolts of lightning in a small glass tube. Even more amazing is the fact you will be able to control the moment each flash occurs with a trigger circuit. Strobe lights

are used to stop motion by adjusting the trigger rate to the speed of a moving object. They are also used to produce light for photography at the moment the camera shutter is opened. In the text that follows, mechanical analogies are used to help explain certain processes that are otherwise difficult to visualize.

THEORY OF OPERATION

WHAT IS A GAS?

All matter is composed of atoms arranged in patterns called molecules. In a solid, these molecules are held in place and cannot move about easily. In a liquid, the molecules move freely, but are still loosely bound to each other. In a gas, the molecules are separated by great distances and bounce about like ping-pong balls in a large box. The molecules of a gas are not bound to each other and will dissipate into the surrounding space if released from their container. These different states of matter are shown in Figure 1.

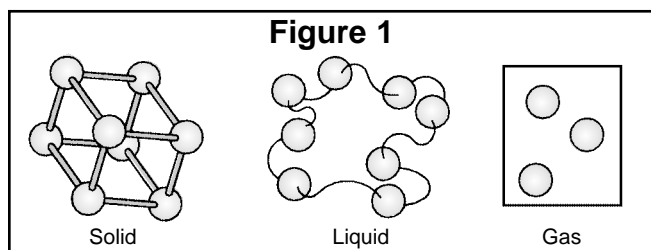

The glass tube in your strobe light kit is filled with a rare gas called Xenon. This gas is used because it is easy to ionize.

WHAT IS AN ION?

Gas atoms have no electronic charge on them in their normal state. There are just as many positively charged protons as there are negatively charged electrons. Therefore, the net charge on the atom is zero. If, however, a negatively charged electron is removed from one of the atoms, the atom is left with a positive charge and it is called a positive ion. This creation of ions is shown in Figure 2.

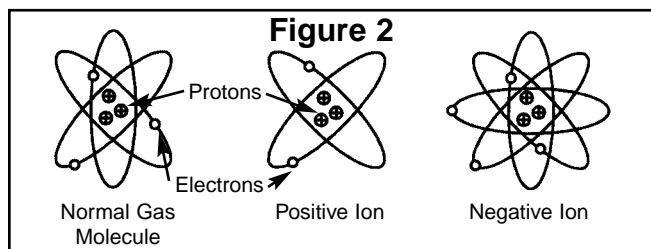

The amount of energy it takes to create an ion is measured in electron volts. Table 1 shows the energy needed to produce ions for different gases. As you can see, Xenon requires much less energy than Neon to produce ions. If the glass tube in your kit contained Neon, the amount of energy needed to ionize the gas would be 1.87 times greater. This would shorten the life of the batteries by using almost twice the energy for each flash. It is a law of nature that opposite charges attract each other and similar charges repel. When a gas molecule is turned into a positive ion, it is attracted to a negative charge. The a positive gas ion is placed in a strong electric field, it will rapidly accelerate toward the negative plate. As it moves, it will strike other gas molecules, knocking electrons free and creating more positive ions. These newly created ions will be attracted by the negative plate, accelerate and create even more positive ions (see Figure 3). The avalanche process will continue until all of the gas in the tube is ionized allowing a large current to flow through the tube and collapse the electric field. As the electrons are knocked about during the ionization process, they release small packets of energy called photons that radiate from the tube. The human eye perceives this burst of photons as a brilliant flash of light.

Gas	Ionization Energy
Helium	24.5
Neon	21.5
Nitrogen	16.7
Hydrogen	15.9
Argon	15.7
Carbon Monoxide	14.2
Oxygen	13.5
Krypton	13.3
Water Vapor	13.2
Xenon	11.5
Mercury	10.4

Table 1

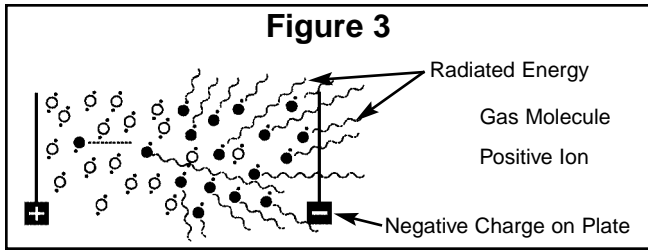

GENERATING AN ELECTRIC FIELD

In order to ionize the Xenon gas in the glass tube, the 3 volts DC at the battery must be transformed into hundreds of volts DC. One of the electronic devices used to “step up” voltages is called a transformer. Transformers, however, only work with AC voltages. You can think of a transformer as a lever similar to the one shown in Figure 4. A small movement on the short end of the lever will produce a large swing on the other end. Since the lever does not create energy, the power on one end must equal the power on the other end. Therefore, the force times the distance on the short end must equal the force times the distance on the other end (as shown in Figure 4).

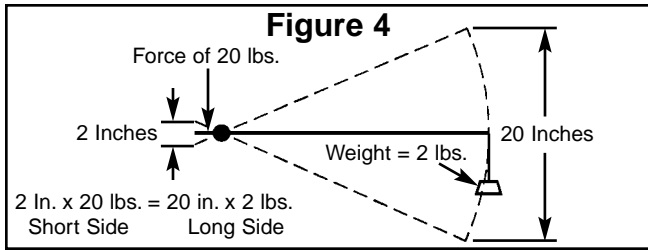

Just like the lever, the transformer must have a moving voltage (AC) to work. If the movement on the short end of the lever equals zero, the movement on the long end will also be zero. Likewise, if DC is applied to one side of a transformer, the output on the other side will be zero. Since the transformer cannot create energy, the power on one side must equal the power on the other side. Electrical power is measured by multiplying the voltage times the current ($V \times I$). Figure 5 shows the method used to transform the 3 volts from the battery to 200 volts needed for a strong electric field.

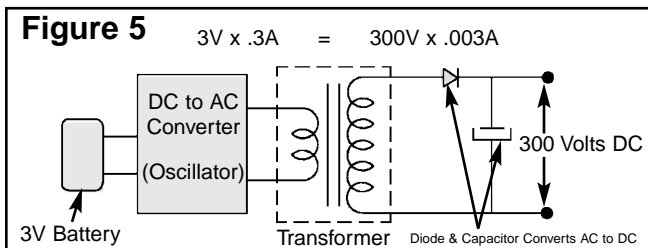

An oscillator is an electronic circuit similar to the

pendulum in a grandfather clock. Once the pendulum is started in motion, it will use only a small amount of energy from the main spring to keep it swinging at the exact same frequency. It is this stable frequency rate that sets the time accurately. If the weight is moved up the stick, the frequency increases. This is called tuning the frequency of the pendulum. In electronics, an oscillator circuit also has tunable elements. The inductor is a tuned electrical circuit is equivalent to the length of the pendulum (see Figure 6).

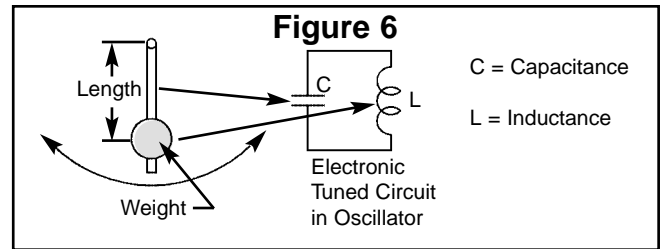

By changing the position of the iron core in the inductor, the inductance can be changed to tune the oscillator to a desired radio frequency, just like changing the weight of the pendulum would change its frequency.

MAKING THE FIRST ION

When the electric field is placed across the Xenon tube nothing happens because there are no ions in the tube to start the avalanche process. A second transformer is used to generate a very high voltage spike on a piece of wire placed along side the tube. This transformer is called the trigger transformer since it “triggers” the avalanche process by forcing a few ions to be produced momentarily in the tube. This process is shown in Figure 7.

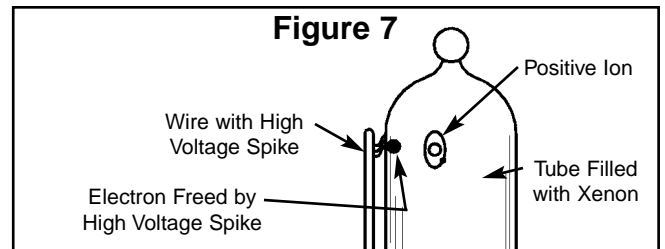

THEORY OF OPERATION

A block diagram is used to break down a system into sub-systems that are easier to explain. All strobe lights will have the blocks shown in Figure 8.

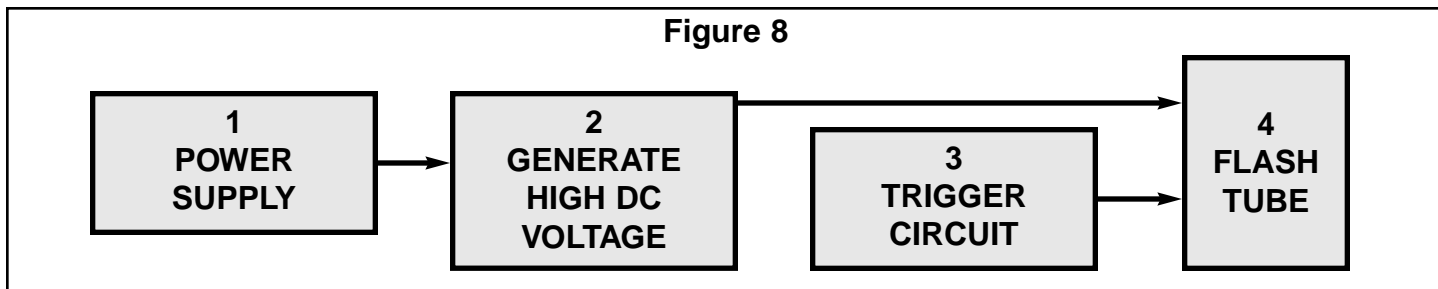

The power supply, Block 1, can be either an AC (Alternating Current) or DC (Direct Current) source of electrical power. When a low voltage DC source is used, a battery for instance, the voltage must be “stepped up” to the proper high voltage required to produce the avalanche process, as shown in Block 2. After the high voltage is generated, a trigger pulse is used to start the avalanche process (Block 3). Once the gas in the flash tube (Block 4) is ionized, the resistance of the tube drops and a large current flows through the tube causing the high voltage to collapse. The gas in the tube returns to its normal state (not ionized) and the process starts over.

BLOCK 1 - Since the power supply in this kit is a battery, it is a DC source. The low DC voltage must be converted to a high DC voltage required by the flash tube.

BLOCK 2 - Figure 5 shows a fundamental high voltage generator. In this kit, a transistor is used for an oscillator (Q1 on schematic drawing shown on page 10). Q1 drives the primary of transformer T1 and the secondary also steps up the voltage needed to flash the xenon tube.

BLOCK 3 - The trigger circuit uses a neon light to fire an SCR (Silicon Controlled Rectifier). The SCR acts like a switch discharging capacitor C4 through the primary of transformer T2. A high voltage spike is produced on the secondary of T2. By using a piece of wire, this trigger voltage is placed close to the glass tube containing the xenon gas.

BLOCK 4 - The flash tube consists of a hollow glass tube filled with Xenon gas and sealed at each end with a metal cap. Wires are connected to each of the metal caps. When a high voltage is placed on one cap and the other cap is grounded, a strong electric field will appear across the tube.

CONSTRUCTION

Introduction

The most important factor in assembling your AK-520 Strobe Light Kit is good soldering techniques. Using the proper soldering iron is of prime importance. A small pencil type soldering iron of 25 - 40 watts is recommended. **The tip of the iron must be kept clean at all times and well tinned.**

Safety Procedures

- Wear eye protection when soldering.
- Locate soldering iron in an area where you do not have to go around it or reach over it.
- **Do not hold solder in your mouth.** Solder contains lead and is a toxic substance. Wash your hands thoroughly after handling solder.
- Be sure that there is adequate ventilation present.

Assemble Components

In all of the following assembly steps, the components must be installed on the top side of the PC board unless otherwise indicated. The top legend shows where each component goes. The leads pass through the corresponding holes in the board and are soldered on the foil side.

Use only rosin core solder of 63/37 alloy.

DO NOT USE ACID CORE SOLDER!

What Good Soldering Looks Like

A good solder connection should be bright, shiny, smooth, and uniformly flowed over all surfaces.

1. Solder all components from the copper foil side only. Push the soldering iron tip against both the lead and the circuit board foil.

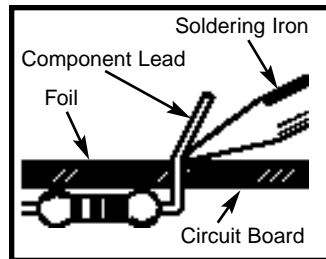

2. Apply a small amount of solder to the iron tip. This allows the heat to leave the iron and onto the foil. Immediately apply solder to the opposite side of the connection, away from the iron. Allow the heated component and the circuit foil to melt the solder.

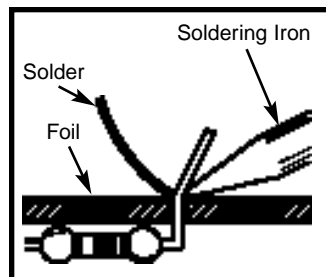

3. Allow the solder to flow around the connection. Then, remove the solder and the iron and let the connection cool. The solder should have flowed smoothly and not lump around the wire lead.

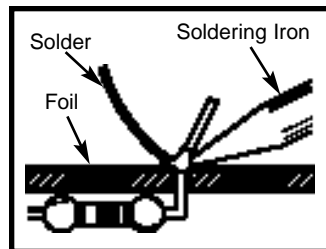

4. Here is what a good solder connection looks like.



Types of Poor Soldering Connections

1. **Insufficient heat** - the solder will not flow onto the lead as shown.

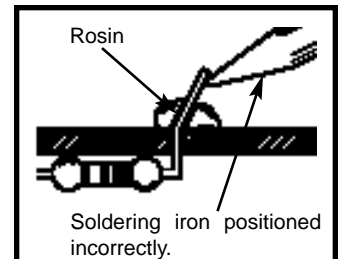

2. **Insufficient solder** - let the solder flow over the connection until it is covered. Use just enough solder to cover the connection.

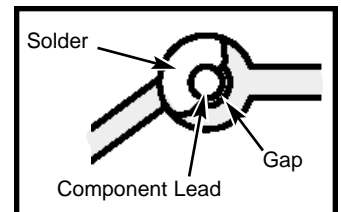

3. **Excessive solder** - could make connections that you did not intend to between adjacent foil areas or terminals.

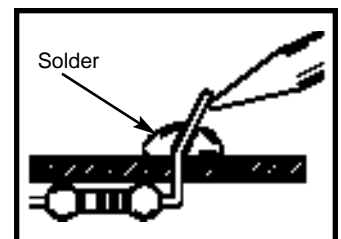

4. **Solder bridges** - occur when solder runs between circuit paths and creates a short circuit. This is usually caused by using too much solder. To correct this, simply drag your soldering iron across the solder bridge as shown.

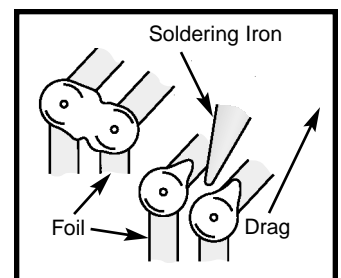

ASSEMBLE COMPONENTS TO THE PC BOARD

- C4 - .47 μ F (474) Mylar Cap.
- C3 - .22 μ F (224) Mylar Cap.
- R1 - 200 Ω 5% 1/4W Resistor (red-black-brown-gold)
- T1 - Transformer
- Q1 - Transistor 2N3904 (Fig. A)
- C1 - .1 μ F (2A104K) Mylar Cap.
- D1 - 1N4148 Glass Diode (Fig. B)
- C2 - 470 μ F Lytic Capacitor (Fig. C)
- BATT - Battery Wires
Solder the black battery holder wire to the BATT (-) Hole marked on the PC board.
- Solder the red battery holder wire to the left lug of the switch.
- Solder the 2" red wire to the BATT (+) hole on the PC board. Then, solder the other end to the middle lug of the switch.

- C6 - .1 μ F (2G104K) Mylar Cap.
- C5 - .01 μ F (103) Mylar Cap.
- SCR - T106D1 SCR (Fig. D)
- D2 - 1N4004 Diode (Fig. B)
- R3 - 2M Ω 5% 1/4W Resistor (red-black-green-gold)
- R4 - 1M Ω 5% 1/4W Resistor (brown-black-green-gold)
- R2 - 1M Ω 5% 1/4W Resistor (brown-black-green-gold)
- NEON - Neon Lamp
- VR1 - 2M Ω Potentiometer
Cut three 3" red wires and solder them to the PC board marked 1-2-3. Then solder the other ends to the 2M Ω pot as shown.
- Cut the tab off of the 2M Ω pot.

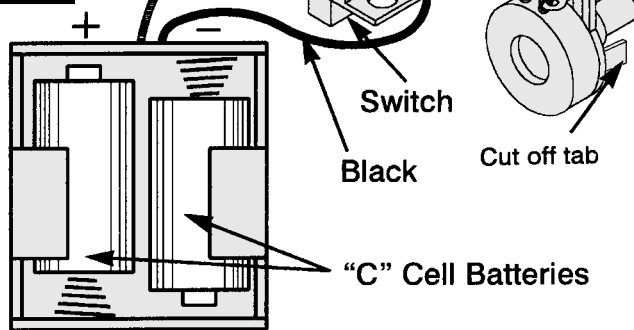
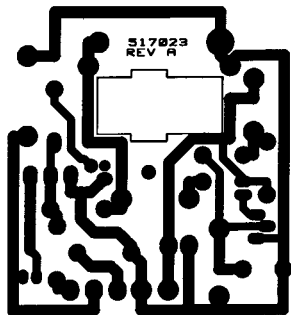
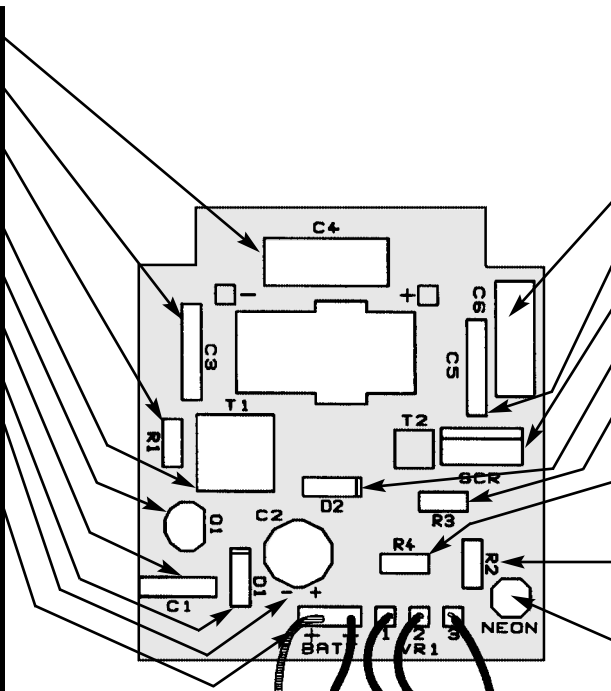

Figure A

Mount the transistor onto the PC board with the flat side in the same direction as shown on the top legend.

Figure B

Diodes have polarity. Mount them with the band in the correct direction, as shown on the top legend.

Figure C

Electrolytics have a polarity marking indicating the (-) lead. The PC board is marked to show the lead position.

Figure D

Mount the SCR in the same direction as marked on the PC board.

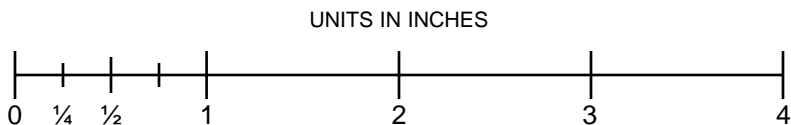

Use this ruler to measure the wires when cutting them to their required lengths.

FINAL ASSEMBLY

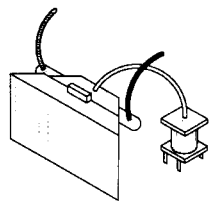

Figure 9

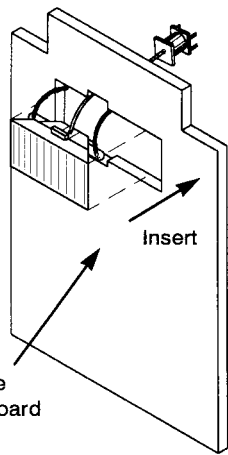

Figure 10

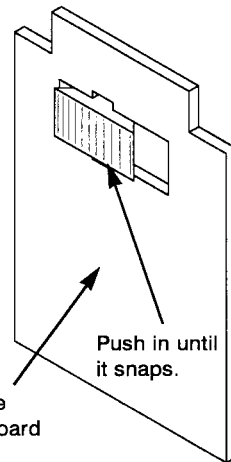

Figure 11

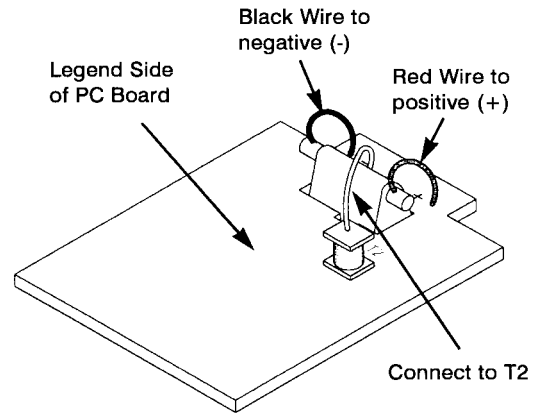

Figure 12

1

□ T2 (See Figure 9) - Insert the assembly as shown in Figures 10-12. Then, solder T2, the black wire, and the red wire to the PC board. (See Figure 12)

2

□ Assemble the PC board, switch and pot to the front panel as shown.

3

□ Remove the backing on both sides of the double-sided tape and apply it to the back of the battery holder. Now, place the battery holder inside of the case as shown in Figure 14.

□ Insert two 1.5V "C" size (alkaline only) batteries into the battery holder.

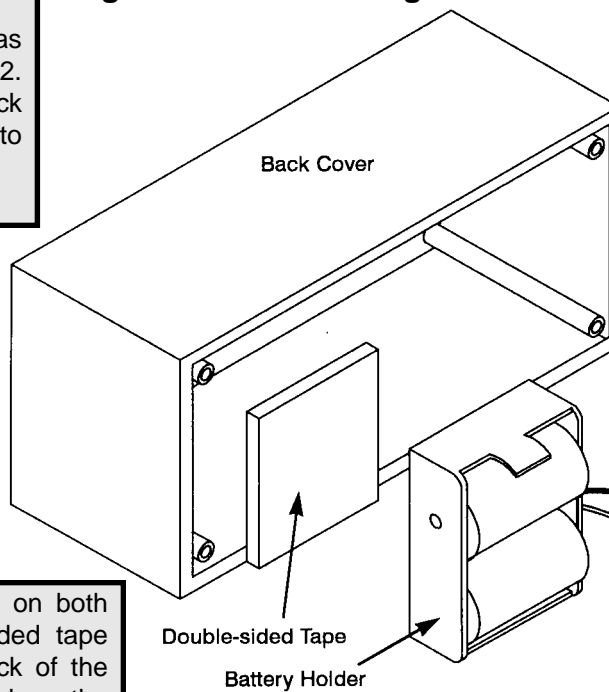

Figure 13

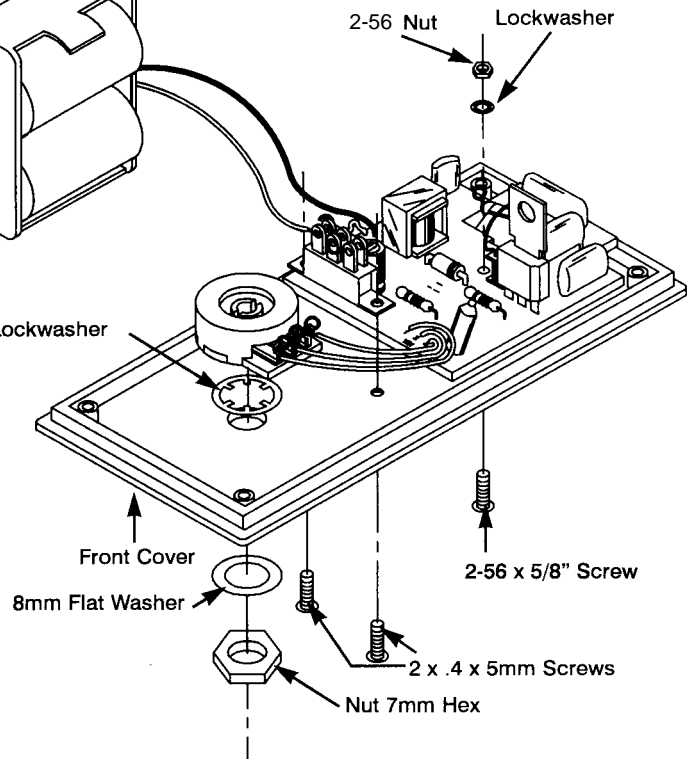
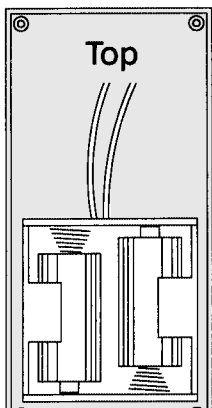

Figure 14



NOTE: Be sure that you place the battery holder at the bottom of the back cover as shown in Figure 14. Also, make sure that both positive (+) battery terminals are pushed up against the battery holder contacts.

Figure 15

□ Place the lid onto the case and secure it with four 4 x 1/2" screws (see Figure 15).

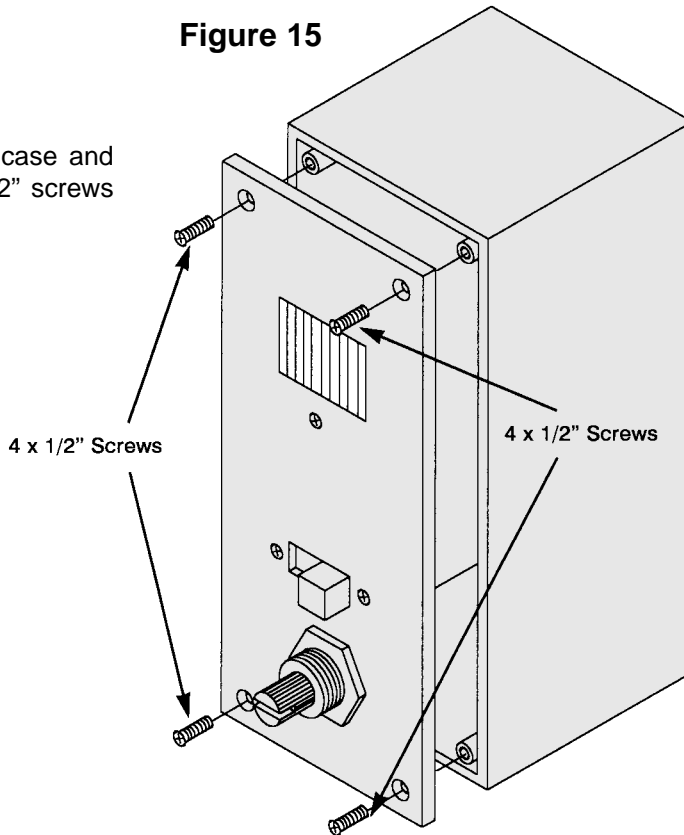
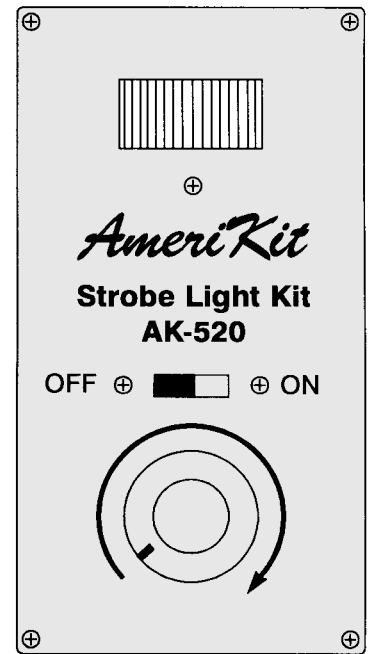

Figure 16



□ Knob - Turn the shaft on the pot counter-clockwise all of the way. Install the knob with the line pointing in the direction as shown in Figure 16.

CAUTION: High voltage present on the PC board. DO NOT handle it while in operation!

OPERATION

1. Turn the unit on and turn the knob fully counter-clockwise. As you adjust the knob clockwise, the flash rate will increase. The maximum flash rate should be at the mid point. After the mid point, the flash rate will decrease and may become erratic.

The maximum flash rate can be adjusted to approximately 4 times per second.

TROUBLESHOOTING

Consult your instructor or contact Elenco Electronics if you have any problems. **DO NOT** contact your place of purchase as they will not be able to help you.

1. One of the most frequently occurring problems is poor solder connections. Tug slightly on all of the parts to make sure that they are indeed soldered.
2. All solder connections should be shiny. Resolder any that are not.
3. Solder should flow into a smooth puddle rather than a round ball. Resolder any connection that has formed into a ball.
4. Have any solder bridges formed? A solder bridge may occur if you accidentally touch an adjacent foil by using too much solder or by dragging the soldering iron across adjacent foils. Break the bridge with your soldering iron.
5. Check the battery voltage with a voltmeter (3VDC).
6. Check the voltage across C4 for 250 - 350V. If less, then check the battery, R1, C1 - C3, Q1, D2 and/or T1. If greater, then check R2 - R4, VR1, Neon, SCR, C6, T2 and/or the flash tube.
7. If the Neon flashes but the strobe light doesn't, then check the SCR, C6, T2, battery voltage and/or the flash tube.

GLOSSARY

AC Voltage	A voltage that varies, usually above and below zero volts, thus causing the current to alternate.
Atom	The smallest part into which matter can be divided and still maintain its identity.
Avalanche	An increase in moving particles due to sudden impact.
Electric Field	The force that exists when a difference in charge occurs.
Electron	A tiny negatively charged particle that rotates around the nucleus of an atom.
Electron-volts	A unit of energy equal to 1.602×10^{-19} joules.
Energy	Effective force. The capacity for doing work.
Force	The cause that changes bodies from a state of rest to motion or from motion to rest.
Gas	An air-like substance without definite shape or volume, tending to expand indefinitely when unconfined. One of the three forms in which matter can exist.
Ion	An electrically charged particle that enables the flow of electricity.
Liquid	One of the three forms in which matter can exist separately and still maintain the character of that substance.
Neon	A gaseous element, inert, colorless, and found in the atmosphere.
Photons	A unit of light measurement.
Power	The mechanical rate at which energy is exerted or work done.
Proton	The smallest unit of positive charge in an atom.
Solid	One of three forms in which matter can exist, having a definite volume and a definite shape.
Transformer	A device used for converting an alternating electric current from one voltage to another.
Xenon	A gaseous element which belongs to the group of inert gases. It occurs in air in minute traces.

QUIZ

1. All matter is composed of atoms arranged in patterns called _____.
2. In their normal state, the net charge on a molecule of gas is _____.
3. When a molecule of gas is positively charged it is called a _____.
4. Xenon requires less _____ than Neon to produce ions.
5. A positive ion will accelerate toward a _____ charged plate.
6. During the ionization and avalanche process, small packets of energy called _____ radiate from the glass tube.
7. The _____ is used to step-up an AC voltage.
8. Electrical power is measured by multiplying _____ times _____.
9. The _____ transformer is used to produce the first ions.
10. A negative ion has on more _____ than it has protons.

Answers: 1. Molecules; 2. Zero; 3. Positive Ion; 4. Energy; 5. Negative; 6. Photons; 7. Transformer; 8. Voltage; Current; 9. Trigger; 10. Electron.

SCHEMATIC DIAGRAM

