

This circuit is an excellent item for parties, dances, etc. The circuit is based on an Integrated Circuit which provides three sharp active filters for each channel. Three independent controls vary the amount of light for low, midrange and high frequencies. In addition, a built-in microphone is incorporated which allows the circuit to capture the ambient sound and to operate without requiring a wire connection to your stereo system. The circuit can handle up to 200W of lights per channel at 110V AC (or 400W at 220V AC).

**Mains Warning:**

**This circuit involves high voltage AC main power wiring. Please note that handling, testing and operating high voltage AC powered equipment can be dangerous when basic safety rules are not followed. If you are inexperienced or not confident in working with high voltage AC powered circuits, we strongly recommend that you DO NOT attempt to use this circuit.**

**Step-by-step Assembly**

Refer to the General Assembly Guide included with the kit for detailed instructions on installation of each component.

**1** Resistors:

<input type="checkbox"/> R0 x 2	0Ω	Black (Jumper Resistor)
<input type="checkbox"/> R1, R2, R4, R13, R14	680Ω	Blue, Gray, Brown
<input type="checkbox"/> R3	100Ω	Brown, Black, Brown
<input type="checkbox"/> R5, R7, R8, R18	2.2 MΩ	Red, Red, Green
<input type="checkbox"/> R6, R9, R10, R16	560 KΩ	Green, Blue, Yellow
<input type="checkbox"/> R11, R12, R15, R17	10 KΩ	Brown, Black, Orange



**2** Rectifier and Zener Diodes:

<input type="checkbox"/> D1, D2, D3	1N4002 or 1N4004 (Rectifier)
<input type="checkbox"/> D4, D5	
<input type="checkbox"/> D6	1N4730 (3.9V / 1W Zener)

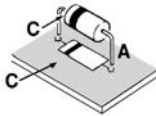

**3** IC Socket:

Install the 14-pin at the location marked "U1". It is recommended to line up the notch on the socket with the notch on the PC board to facilitate the installation of the IC later.

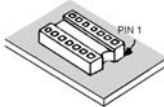

**4** Polyester Capacitors:

<input type="checkbox"/> C3, C4	153 / 0.015 μF / 15nF
<input type="checkbox"/> C5, C8	472 / 0.047 μF / 4.7nF
<input type="checkbox"/> C6, C7	473 / 0.047 μF / 47nF



**5** Terminals:

- Install the 4 metallic terminals at locations marked "L1", "L2", "L3" and "L".
- Install the 5 terminals with plastic bases at locations marked "A1", "G", "A2", "S" and "P".

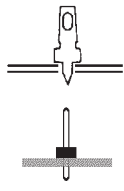

**6** 3-Pin Jumper Header:

- Install the 3-pin jumper header at locations marked "J1". Then place the small plastic jumper head on the topmost two pins (the "A" position).

**7** Electret Microphone:

- Install the microphone at location marked "MIC" by inserting the microphone pins into the PC board making sure that the negative pin (the one connected to the body of the microphone) is inserted into the hole marked with a "-" sign.

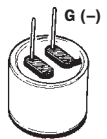

**8** Fuse Holders:

- First place the three fuse holders on the metallic ends of the fuse. Then, install the fuse and the fuse holders at locations marked "F1", "F2", "F3".

**9** Isolation Transformer:

- Install the isolation transformer at location marked "XFMR".

**10** Electrolytic Capacitors:

<input type="checkbox"/> C1	1000 μF / 16 V
<input type="checkbox"/> C2	3.3 μF / 50 V
<input type="checkbox"/> C9	470 μF / 16 V
<input type="checkbox"/> C10, C11	1 μF / 50 V

Remember that the electrolytic capacitors are polarized and they must be oriented properly prior to being soldered.

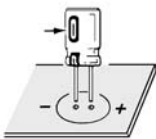

**11** Integrated Circuit:

- Insert the LM3900 IC into the socket by orienting the IC so that the notch is lined up with the notch on the PC board and the socket. Carefully, make sure every pin is lined up with its corresponding hole in the socket. Then, press down firmly and gently on the IC.

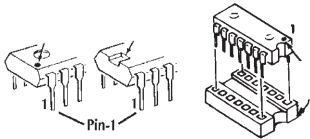

## 12 Light Emitting Diodes (LEDs):

- Install the LED at the location marked "LED1". Note that the anode (A) lead of the LED is longer than its cathode (C) lead. Make sure you insert each LED lead through the appropriate hole in the PC board.

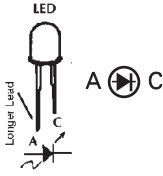

## 13 Triacs:

- Mount the 3 Triacs on the heat sinks using the three screws provided. Then install the Triacs at locations marked "Q1", "Q2", and "Q3". Make sure you line up the heat sinks

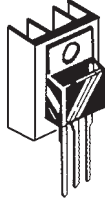

## 14 Potentiometers:

- P1, P2, P3          20 K $\Omega$

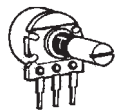

## Testing

Before testing the kit, It is highly recommended to inspect the PC board carefully as explained below:

- Check for proper placement of all components.
- Check for proper orientation of the LED, diode, electrolytic capacitors, triacs and the integrated circuit.
- Check IC pins to see that they are not folded under.
- Check for protruding leads which could touch other leads or adjacent pads.
- Check all solder connections for cold solder joints.
- Examine the PC board solder side to see that there are no solder bridges causing shorts between tracks.

Once you are satisfied that everything is correct, proceed to do the test as follows: (Refer to wiring diagram.)

1. Place the small plastic jumper head on the topmost two pins of "J1" (the "A" position) to select the microphone input.
2. To power the circuit, you need an 18V AC C.T. / 100mA transformer. Connect the transformer to the points marked "A1", "G" and "A2". Make sure that the centre wire of the transformer is connected to the point marked "G".
3. Before plugging in the transformer, do the wiring between the lights and the circuit as shown in the wiring diagram. You will need at least 3 lights, but you can connect up to a maximum of 200W per channel (for example ten 20W lights per channel).

# Canakit

www.canakit.com

Manufacturer of High Quality Electronic Kits

### Important Note:

*Do not touch the PC board or any of its components when the circuit is connected to the AC line as some of the components and tracks on the board will be carrying high AC voltage. Also note that there is high AC voltage on the metallic part of the three triacs.*

*For safety it is highly recommended to install the circuit in a fire resistant plastic box and to cover any external wire connections using electrical tape. If you are inexperienced or not confident in working with high voltage AC powered equipment we strongly recommend that you DO NOT attempt this circuit.*

4. Once you are sure that all connections have been made correctly, plug in the transformer and the lights. The lights should now turn on and off according to the ambient sound captured by the built-in microphone. You can control the sensitivity of each channel using the potentiometers "P1", "P2" and "P3" to control channels "L1", "L2" and "L3" respectively.
5. The circuit can also operate by direct connection to your stereo system. To place the circuit in this mode, place the small plastic jumper head on the bottommost two pins of "J1" (the "B" position). In this mode of operation the built-in microphone will be disabled.

**Make sure the circuit and the lights are disconnected from the AC line before touching any of the components on the board since some of the components on the board carry high AC voltage.**

To connect your audio source to the circuit, connect the speaker output to the points marked "S" and "P". Note that you can connect the circuit in parallel with one speaker in order to have both the circuit and the speaker connected at the same time. If your audio source is stereo, simply use one of the channels. **Do not connect both channels to the circuit at the same. You can damage your audio source if you do so.**

Manufactured by:

**Canakit Corporation**

**(Unikit is a division of Canakit Corporation)**

#121 – 3823 Henning Drive

Burnaby • BC • V5C 6P3 • Canada

Email: info@canakit.com

**Web Site: www.canakit.com**

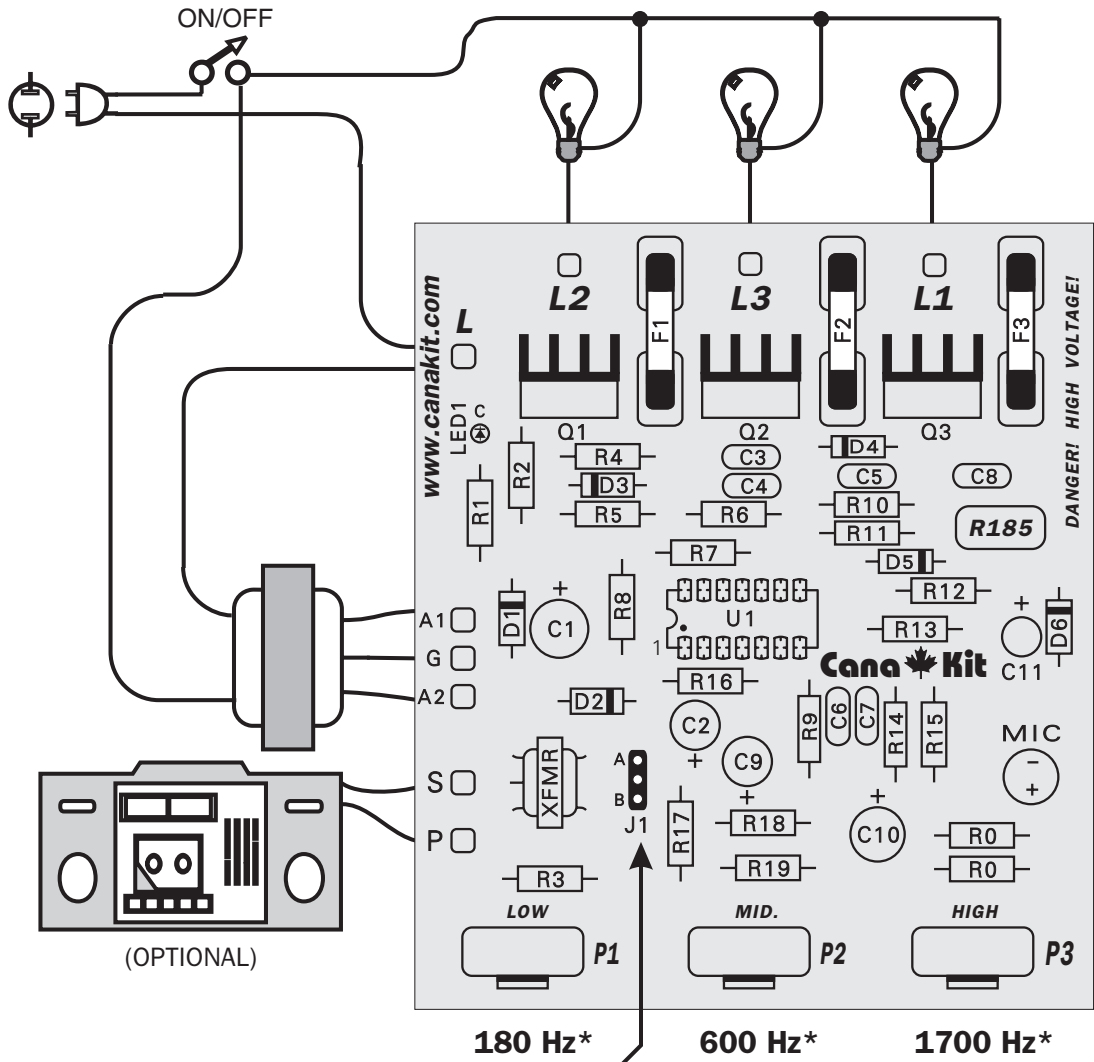

(OPTIONAL)

180 Hz\*

600 Hz\*

1700 Hz\*

\* Centre frequency of each channel

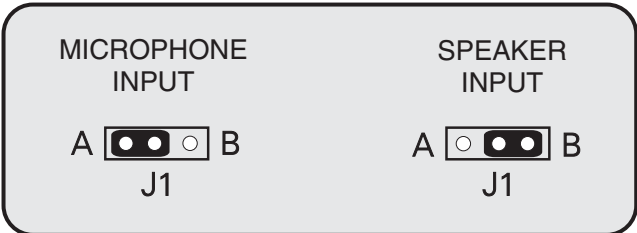

**Wiring Diagram**

**WARNING!**

**This kit is not isolated from the AC main and presents a serious safety hazard if body contact is made anywhere to the circuit.**

**Never touch any of the parts while the unit is connected to the AC main.**

**We highly recommend you to house the kit in a non-conductive heat resistant enclosure.**

