

5-Channel Multi-Program Light Chaser with Triac Board

This circuit is a versatile 5-channel AC light chaser that is easy to program. The circuit incorporates 5 jumpers that can be positioned on 2 different positions in order to create numerous types of moving light effects. Each channel can handle up to 200W. A PC board mounted adapter jack is included.

WARNING:

This kit involves high voltage AC power wiring. Please note that handling, testing and operating high voltage AC powered equipment can be dangerous when basic safety rules are not followed. If you are inexperienced or not confident in working with high voltage AC powered circuits, we strongly recommend that you DO NOT attempt this kit.

Step-by-step Assembly

Refer to the **General Assembly Guide** included with the kit for detailed instructions on installation of each component.

1 Resistors:

<input type="checkbox"/> R1, R2, R3, R4, R5	220Ω	Red, Red, Brown
<input type="checkbox"/> R6, R7, R8, R9, R10	2.2 KΩ	Red, Red, Red
<input type="checkbox"/> R11, R12, R13, R14, R15	1 KΩ	Brown, Black, Red
<input type="checkbox"/> R16, R17, R18, R19, R20	5.6 KΩ	Green, Blue, Red
<input type="checkbox"/> R21	820Ω	Gray, Red, Brown
<input type="checkbox"/> R22	390 KΩ	Orange, White, Yellow
<input type="checkbox"/> R23	4.7 KΩ	Yellow, Violet, Red
<input type="checkbox"/> R0 x 6	0Ω	Black (Jumper Resistor)

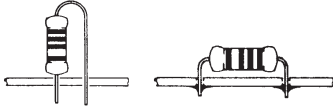

2 Rectifier Diode:

D1 1N4002 / 1N4004

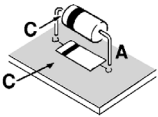

3 IC Socket:

Install the 16-pin IC socket at location marked "U1". It is recommended that the notched end be aligned with the outline on the PC board to facilitate installation of the IC later.

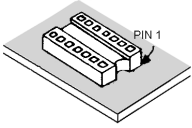

4 Trimmer Potentiometer:

Install the 10 K trimmer potentiometer at location marked "P1".

5 Ceramic Capacitor:

C2 224 / 0.22 μF / 220 nF



6 Terminals with Plastic Bases:

Install the 2 terminals with plastic bases at locations marked "DC".

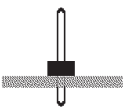

7 3-Pin Headers:

Install the five 3-pin headers at locations marked "J1" – "J5". Then place the five small plastic jumper heads on the "B" positions.

8 Metallic Terminals:

Install the 6 metallic terminals at locations marked "L1", "L2", "L3", "L4", "L5" and "MAIN".

9 Fuse Holders:

First place the two fuse holders on the metallic ends of the fuse. Then install the fuse and the fuse holders at location marked "FUSE".

10 Transistors:

<input type="checkbox"/> Q1, Q2, Q3, Q4, Q5	Q6, Q7, Q8, Q9,	2N4124 (NPN)
<input type="checkbox"/> Q10, Q12		2N4126 (PNP)
<input type="checkbox"/> Q11		



11 Adapter Jack:

Install the adapter jack at location marked "JACK".

12 Electrolytic Capacitor:

C1 470 μF / 16 V

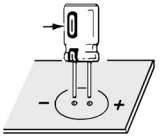

13 Light Emitting Diodes (LEDs):

Install the five LEDs at location marked "LED1", "LED2", "LED3", "LED4" and "LED5". Note that the longer pin of each LED is the anode and must be inserted into its corresponding hole.

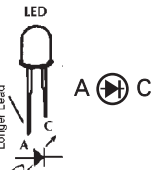

14 Triacs:

Install the five triacs at locations marked "TR1", "TR2", "TR3", "TR4" and "TR5". Make sure that the metallic side of each Triac is lined up with the thick line marked on the PC board (facing the letters "TR1" – "TR5").

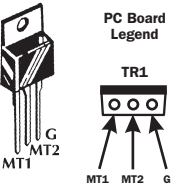

15 CMOS Integrated Circuit:

Insert the 4017 integrated circuit at location marked "U1". Make sure the IC is oriented correctly. Note that this IC is of type CMOS and static electricity can damage it. Follow the instructions in the General Assembly Guide in order to handle it correctly.

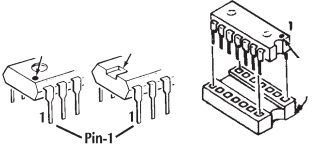

Testing

Before testing the kit, It is highly recommended to inspect the PC board carefully as explained below:

- Check for proper placement of all components.
- Check for proper orientation of the transistors, LEDs, electrolytic capacitors, diodes and triacs.
- Check for proper orientation of the IC.
- Check IC pins to see that they are not folded under.
- Check for protruding leads which could touch other leads or adjacent pads.
- Check all solder connections for cold solder joints.
- Examine the PC board solder side to see that there are no solder bridges causing shorts between tracks.

Once you are satisfied that everything is correct, proceed to do the test as follows: (Refer to wiring diagram.)

1. Before wiring the lamps and connecting the circuit to a high voltage AC line, the circuit needs to be tested for proper operation. In order to do so, the circuit needs to be supplied by a DC voltage source to operate. You can either use a standard 9V DC (**centre positive polarity**) adapter connected to the adapter jack or a 9 – 12 V DC supply voltage connected to the points marked “DC”.
2. Once the DC supply has been applied to the circuit, the LEDs should start illuminating one after the other. You can change the positions of the jumpers “J1” – “J5” to the “A” position in order to create different effects. For example, if you position all the jumpers on the “A” position, the lighting effect is “reversed” creating the an illumination effect which resembles a black moving dot rather than a single moving light. Refer to the figures below for an illustration.

Important Note:

Do not touch the PC board or any of its components when the circuit is connected to the AC line as some of the components and tracks on the board will be

carrying high AC voltage. Also note that there is high AC voltage on the metallic part of the triacs. For safety it is highly recommended to install the circuit in an appropriate box and to cover any external wire connection using electrical tape. If you are inexperienced or not confident in working with high voltage AC powered equipment we strongly recommend that you DO NOT attempt this kit.

3. Once you have performed the preliminary test and you have positioned the jumpers to your desired position, you can proceed to connect the outputs of the circuit to the lamps to be controlled (up to a maximum of 200W per channel). In order to create different lighting effects connect multiple lights to each channel and arrange them as desired. Refer to the wiring diagram in order to do the AC wiring. As mentioned above, be very careful when wiring high AC voltage connections. If you are not confident doing the AC wiring yourself, you can seek the help of a qualified electrician in order to do the AC wiring for you.

Wiring Diagram

DANGER! HIGH VOLTAGE

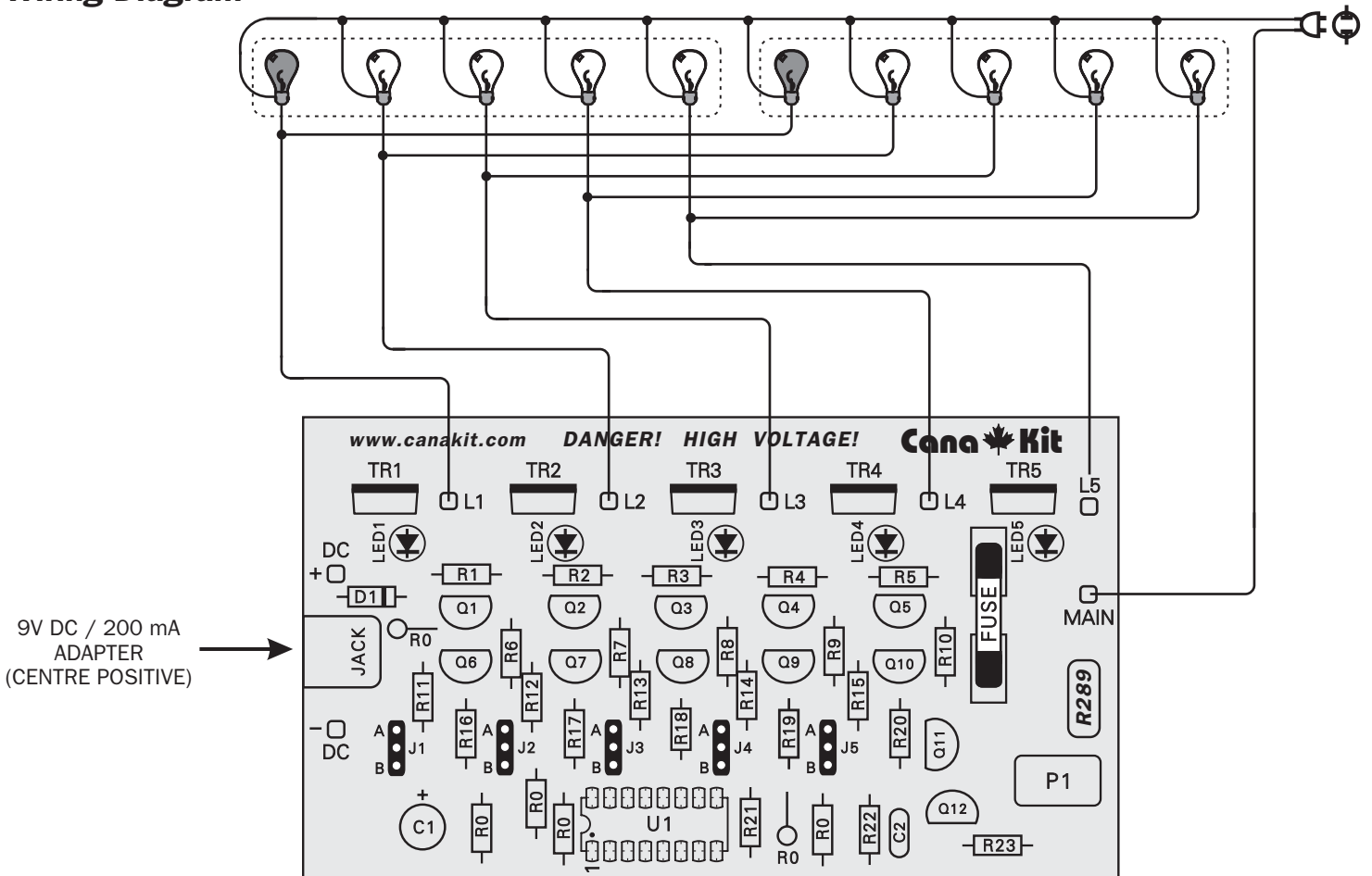

Note: Above configuration creates a “running” lights effect using 10 lamps (2 lamps per channel). You can add more lamps per channel up to a total of 200W per channel. You can see the different effects crated depending on the position of the five jumpers in the figures below. These examples use a total of 30 lamps (6 laps per channel).

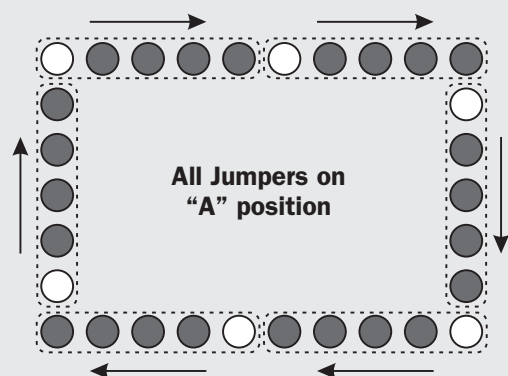
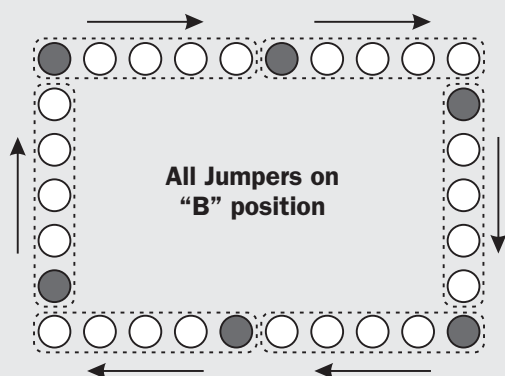

Schematic Diagram

Manufactured by:
Cana Kit Corporation
(Unikit is a division of Cana Kit Corporation)
#121 – 3823 Henning Drive
Burnaby • BC • V5C 6P3 • Canada
Email: info@canakit.com
Web Site: www.canakit.com

Copyright © 1990 – 2003 Cana Kit Corporation
All rights reserved
Reproduction without prior written permission is strictly prohibited