

# CK104 - GENERAL PURPOSE 3 1/2 DIGIT PANEL METER

The 7106 chip is one of the long term survivors in the IC world. It was launched in 1977 yet it has remained as popular as ever. The reason is that it contains in it all the active circuitry for a 3 1/2 digit panel meter (DPM) in a single chip. It was designed to interface directly to a liquid crystal display (LCD). (It has a sister chip, the 7107, intended for connection to light emitting diode displays.) So the chip contains BCD to seven segment decoders, display drivers, clock and a reference voltage as well as the necessary analog to digital (a/d) circuitry to convert the input voltage to a digital form. The a/d system also indicates the polarity of the input voltage.

Voltage is the most frequently measured electrical quantity. In temperature meters, current meters, wind speed meters and resistance meters what is actually being measured is voltage, or more correctly, the potential difference between two points. After calibrating the meter for its particular purpose then the potential difference measured will give an accurate digital reading of the analog quantity being measured.

With less than 10 external passive components the 7106 chip may be made into an easy to use meter for any of these purposes especially multiple range digital volt meters.

Digital displays have many advantages over analog meters which use a pointer and moving coil. Firstly they are easier to read especially by unskilled labour. In the majority of applications it is better that the value displayed is exactly the value being measured, for example, 13.6V. To use an analog display with its many graduated scales (some going up and others going down) and switches requires considerable practice. But a simple LCD which reads '13.6' can be understood by everyone.

Second, DPM built using the 7106 are physically stronger and more robust than analog meters because they have no moving parts. Thirdly, for the manufacturer the assembly of the complete DPM unit can be done by unskilled labour in third world countries - Philippines, China, Bangladesh. Fourthly, the 7106 by its very nature can be adapted to so many uses at such a low cost that it has actually created markets for itself. All of these factors add up to a better, cheaper product which everyone can afford.

In this Kit we have supplied the 7106, the LCD and the essential components and information necessary for you to custom build it into a panel meter of your choice. The display has been constructed so that you can cut it off and locate it some distance away from the main circuit board. The PCB has a printed overlay on it so that the position of all the components is clearly indicated and construction only takes a few minutes.

The kit is constructed on a single-sided printed circuit board (PCB). Protel Autotrax and Schematic were used to design it.

## ASSEMBLY INSTRUCTIONS

Assembly is generally straight forward. Follow the overlay to tell you where to put the components. There are several important points to watch.

1. The LCD is mounted on two 40 pin IC sockets which you must cut apart using your side cutters. This allows the LCD to sit above the 7106 chip. Make sure you get the LCD and the 7106 chip around the correct way. Look for the notch in the LCD and the 7106 and make sure they correspond to the notch shown on the PCB overlay for those components. These two components should be the last items added to the PCB.
2. There are **4 LINKS** to connect on top of the PCB.
3. There are no components supplied in the Kit for  $R_{X1}$ ,  $R_{X2}$ ,  $R_{Y1}$ ,  $R_{Y2}$  or R. These depend on how you use the Kit. **BUT** you should connect a 10M resistor for  $R_{Y1}$  when you calibrate the meter. Because the input resistance to the meter is so high this resistor is necessary to short out any static charges accumulating on the input terminals.

## WHAT TO DO IF IT DOES NOT WORK

Poor soldering is the most likely reason. Check all solder joints carefully under a good light. Next check that all components are in their correct position on the PCB. Thirdly, follow the track with a voltmeter to check the potential differences at various parts of the circuit.

A check list of other items includes:

- did you add the 4 jumper links on top of the PCB,
- are the IC and LCD in the correct way. Check no pins are bent up. This is very easy to do with a 40 pin IC and LCD display.
- is the battery fully charged.

## CIRCUIT DESCRIPTION

The heart of the meter is the a/d converter built into the 7106. It uses a dual slope conversion technique. It relies on the charging and discharging of an integrating capacitor and having a counter count when the capacitor voltage is above a set value. Since the capacitor discharge is linear the counter reading is proportional to the input voltage. There are three phases to the process:

**Phase 1.** Auto Zero. The autozero capacitor is charged to the integrators offset voltage. This voltage is subtracted from the input signal during phase 2. The integrator thus appears to have zero offset voltage.

**Phase 2.** Signal Integrate. The signal input is averaged for 1000 clock pulses.

**Phase 3.** Reference Integrate.  $V_{REF}$  is averaged back to zero volts. The number of clock pulses counted to return to zero is a digital measure of  $V_{IN}$ .

The Reference Voltage supplied to the 7106 at pins 30 and 31 should be between 100mV and 1V for most

# CK104 - GENERAL PURPOSE 3 1/2 DIGIT PANEL METER

purposes. As we will see below this corresponds to a full scale reading of 199.9mV and 1.999V respectively. Components supplied in this Kit are for a  $V_{REF}$  of 100mV. For a  $V_{REF}$  of 1V only two components should be changed to maintain sensitivity and recovery from over-voltage.

Let us discuss parts of the circuit in more detail and investigate how to customise the meter for your purpose.

**Decimal Point.** A jumper selects the decimal point position in the LCD. Displays are driven by applying a symmetrical square wave to the back plane (BP.) To turn on a segment a waveform 180° out of phase with the BP (but of equal amplitude) is applied to that segment. To get the decimal point the external circuit inverts the BP output (pin 21) with an FET and applies it to the required decimal point by the jumper. Pin 37 is used as the negative supply for these externally generated segment drivers.

**Analog Section.** C1 is the reference capacitor and is unchanged for all ranges measured. IN LO is tied to the analog COMMON pin 32.

The integration capacitor C5 is suitable for all ranges measured but the value of the integration resistor R1 should be increased to 470K for a  $V_{REF}$  of 1V.

**System Timing.** This is determined by the components connected to pins 38, 39 & 40. Values are unchanged for all ranges measured. The internal oscillator runs at 48kHz, or 3 readings per second.

**Auto-Zero Capacitor.** This is C4 connected to pin 29. It has some influence on the noise of the system and recovery from overload input. For 200mV full scale 0.47uF is recommended. On the 2V scale a 0.047uF capacitor may give better results.

**Reference Voltage.** The analog input required to generate a full scale output of 2000 counts is

$$V_{IN} = 2 \times V_{REF}$$

Thus to set the meter to read from 0 - 199.9mV,  $V_{REF}$  should be set to 100.0mV.

To set the meter to read a full scale reading of 0 - 1.999V,  $V_{REF}$  should be set to 1.000V.

The reference voltage must be between 100mV and 1V.  $V_{REF}$  is measured between pins 30 & 36. Pads have been provided on the main circuit board and on the bottom layer under the 7106 for convenient access. The POT is adjusted to get the correct reference voltage.

To measure voltage greater than 2V an input voltage divider is required. See Figure 1 The general relation for full scale sensitivity is now:

$$V_{IN} \text{ (full scale)} = 2V_{REF} \times R_Y / (R_X + R_Y)$$

This is the purpose of the space for 4 resistors on the main circuit board. Note that it is not necessary to get exact values of resistances as the  $V_{REF}$  can be adjusted using the potentiometer.

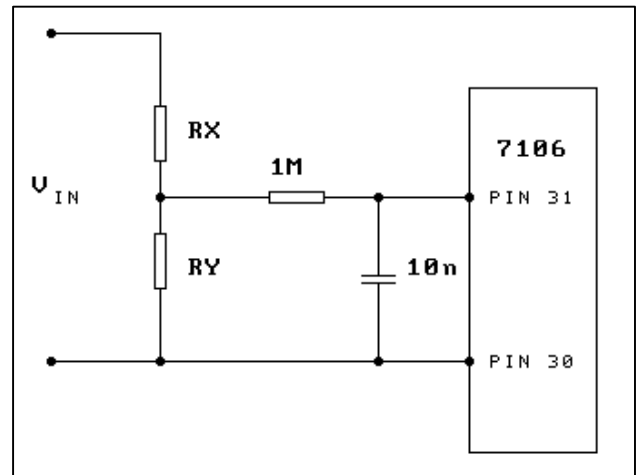

Figure 1. Principle of Current Measurement.

For example, a 0 - 20V range can be obtained using a 10:1 voltage divider. This can be done by making  $R_X = 900K$  and  $R_Y = 100K$ . 900K is not a standard value but it can be obtained by putting two 1M8 resistors in parallel. That is,  $R_X = R_{X2} = 1.8M$ . The decimal point jumper is placed at position '2' so a full scale display of 19.99V is available. See the Table at the bottom of the next page.

Similarly, a 0 - 200V range can be obtained with  $R_{X1} = 1M8$ ;  $R_{X2} = 2M2$  and  $R_Y = 10K$ . The decimal point jumper is moved to position '3'. Putting this all together we can construct a multirange voltmeter as shown in Figure 2.

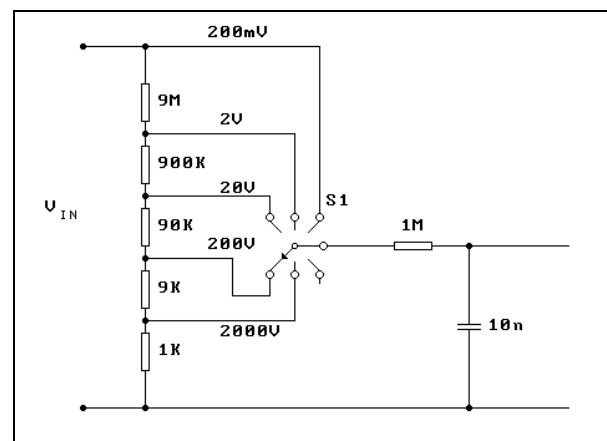

Figure 2. Multirange Voltmeter

**Non-standard Voltage Input.** In many applications it is required that the output of a transducer is converted by a scale factor into some meaningful result. For example, a load cell of a weighing system may have an output voltage of 0.682V when it has 2.0 Kg weight on it. You want the meter to read the range 0 - 1.99 Kg directly.

# CK104 - GENERAL PURPOSE 3 1/2 DIGIT PANEL METER

It is an easy matter to adjust  $V_{REF}$  to 0.341V (half the output voltage), put the decimal point in the correct position by moving the jumper and the panel meter now reads off 0 - 1.99 Kg directly from the display.

**Current Measurement.** The current must be converted into a voltage using a shunt resistor. Space is provided on the board to place up to a 5W shunt resistor R. The voltage divider resistors  $R_X$  and  $R_Y$  are not used. The principal is shown in Figure 3.

If  $R = 0.1$  ohms then 200mV will be developed when the current through it is 2A. This voltage is applied to the meter which is set up for the 200mV range. (That is,  $V_{REF}$  is set to 100mV.) Power dissipation at the maximum reading is  $I^2R$  which is 0.4W, well within the 5W rating of the resistor. See the Table on the next page.

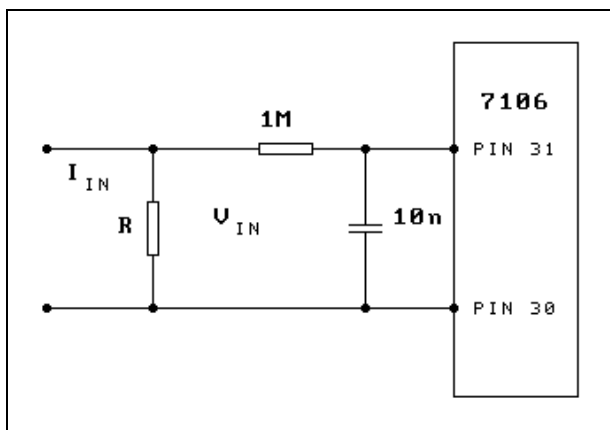

Figure 3. Principle of Current Measurement.

To measure a full scale of 200mA then R should be 1.0 ohms in order to generate 200mV input to the meter. For a 20 mA meter then  $R = 10$  ohms.

A general multirange current meter is shown in Fig. 4

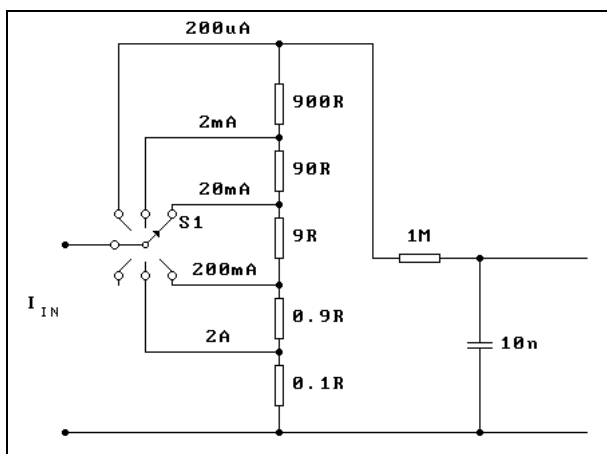

Figure 4 Multirange Current Meter.

**Temperature Measurement.** Kit 2 from DIY Electronics is a 7106 panel meter specifically dedicated to measuring temperature. The number of external passive components

is a few more than required for voltage or current measurement but the principles are exactly the same.

**Voltages Below 200mV.** On the 200mV scale the least significant digit represents 100 micro volts. To resolve smaller signals it is necessary to use an op-amp prior to the voltage input.

**Resistance Measurement.** The Kit is not specifically designed for this purpose, however, with some changes to the board this function can be carried out. The principle is shown in Fig. 5. The unknown resistance is put in series with a known resistance and a current passed through the pair as shown. If they are of equal value the integration and deintegration ramps will be of equal slope and the display will read 1000. The maximum readable ratio is 1.999. Since a ratio is being measured the reference resistor need not be exact.

$$\text{Displayed reading} = R_{\text{unknown}}/R_{\text{standard}} \times 1000$$

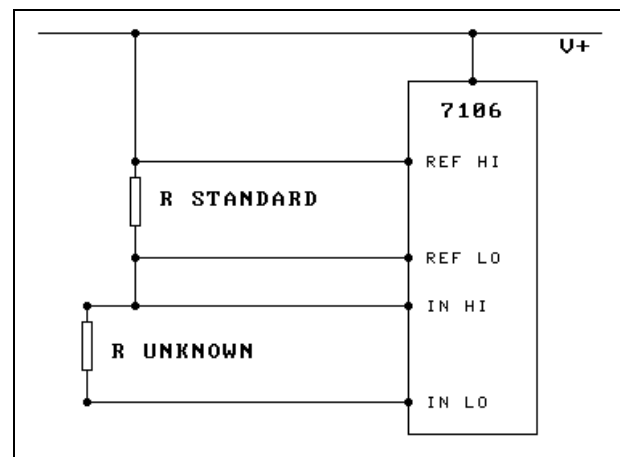

Figure 5 To Measure Resistance.

## WHAT TO LEARN FROM THIS KIT

The Kit shows how much of electronics today can be contained in a single chip. Commercial low to medium cost digital multimeters are nothing more than this kit, some switches and passive components and a plastic case. The main reason today for the failure of meters is more likely due to switch contact and mechanical failure rather than failure of the electronics itself.

The data sheet for the 7106 may be downloaded from the Intersil website at

[www.intersil.com](http://www.intersil.com)

