

# CK1700 PIC16F84A PROGRAMMER & EXPERIMENTER

**November, 2002.** This is completely new **software** and **documentation** for CK1700. The Kit hardware remains the same. Over the last couple of years the old documentation became out of date as new PIC chips were released and software and operating systems progressed. And the old DOS-based software was itself a difficult thing for Windows-raised people to learn.

Now we provide

- easy to use Windows 9x/NT/2000 programming software
- 4 detailed code examples
- a 40 page Manual (pdf)

And we introduce the MPLAB program from Microchip to do program development and assembly.

The Kit connects to the parallel port of a PC. You program the 16F84A using the software provided, then move the programmed 16F84A IC from the IC4 socket to the TEST CIRCUIT IC socket. When you reconnect power the 5 LEDs should flash in the pattern you programmed.

Thus we guarantee that your first programming efforts are successful. We provide the fully commented source code for 4 program which flash the LEDs in a variety of patterns: binaryup.asm, binarydn.asm, binarylr.asm and flash.asm. The compiled object code is also provided: the hex files.

You use the software **diy81.exe** to program the hex file into the PIC chip.

## How to Proceed.

1. Download the software from

<http://www.electronickits.com/kit/complete/prog/ck1700soft.zip>

Unzip it to a temporary directory and run setup. This creates a directory c:\diy81. Make an icon on the Windows desktop for **diy81.exe**. Follow the instructions in the **drivers.txt** file. Then run the software and check that the program comes up on the screen.

2. Print out the **k81.pdf** manual. The schematic and assembly instructions are in it as well as Introductory Programming Tutorial.

3. Assemble Kit 81. Connect it to a parallel port on your PC. Add power to the board. Run the Test button to see that the PC connects to the Kit.

4. If the Test is OK then press Program and with the 16F84A in IC4 select **binarylr.hex**. Note the programming sequence: erase, programming, fuses set. After it is completed remove the power and move the OIC to the TEST socket. Connect the power. The LED's should run left-right-left. Print out the commented source code **binarylr.asm**.

5. Now it is up to you to use the Tutorial, the examples given and any other PIC books you have to learn to program. For example, a good set of books are to be found at

<http://www.sq-1.com/>

Buy *Easy Microcontrol'n* first.

6. When you feel ready you will have to download MPLAB as outlined on page 27 of the Tutorial. Here are the current details of how to do it. Try not to let the complexity and size of the program intimidate you. The learning curve is steep but stay with the PIC16F84A only and follow the Tutorial outline.

Log onto <http://www.microchip.com/>

Click on Development Tools>Development Software>MPLAB@IDE

Now I suggest you click on the MPLAB@IDE v5.70.... the second in the list. This is the well tested version. Later V6 and higher still has minor bugs and that is the last thing you need.

Click D/L the full 13.73MB of MPLAB@5.7.

After you have it I suggest you also get the MPLAB@Manual & Tutorial from the Documentation lower down the page. Maybe print it out.

## Conclusions.

1. You now have the Introduction and Tools to learn quite a bit about programming the PIC16F84A. It is now up to you to work at your own pace through the examples provided. Vary the examples to flash LED's differently. Program to flash the LEDs by different methods of code.

Then you can use the programmer to program the 16F84A independently of the Test Circuit. It is a 16F84A programmer in its own right. And combined with the free MPLAB you have a cheap and powerful entry point into microcontroller programming.

There are many schematics on the Web using the 16F84A. The magazine [Everyday Practical Electronics](#) in the UK publishes a PIC project almost every month currently.

2. When you outgrow the Kit 81 and want to program other members of the Microchip family look at buying one of my other programmers: Kit 96, Kit 144 or Kit 149 (out 12/2002.) The documentation for each of them is on my website.

See our website at

<http://www.ElectronicKits.com>

# CK1700 - 16F84 PIC PROGRAMMER V4

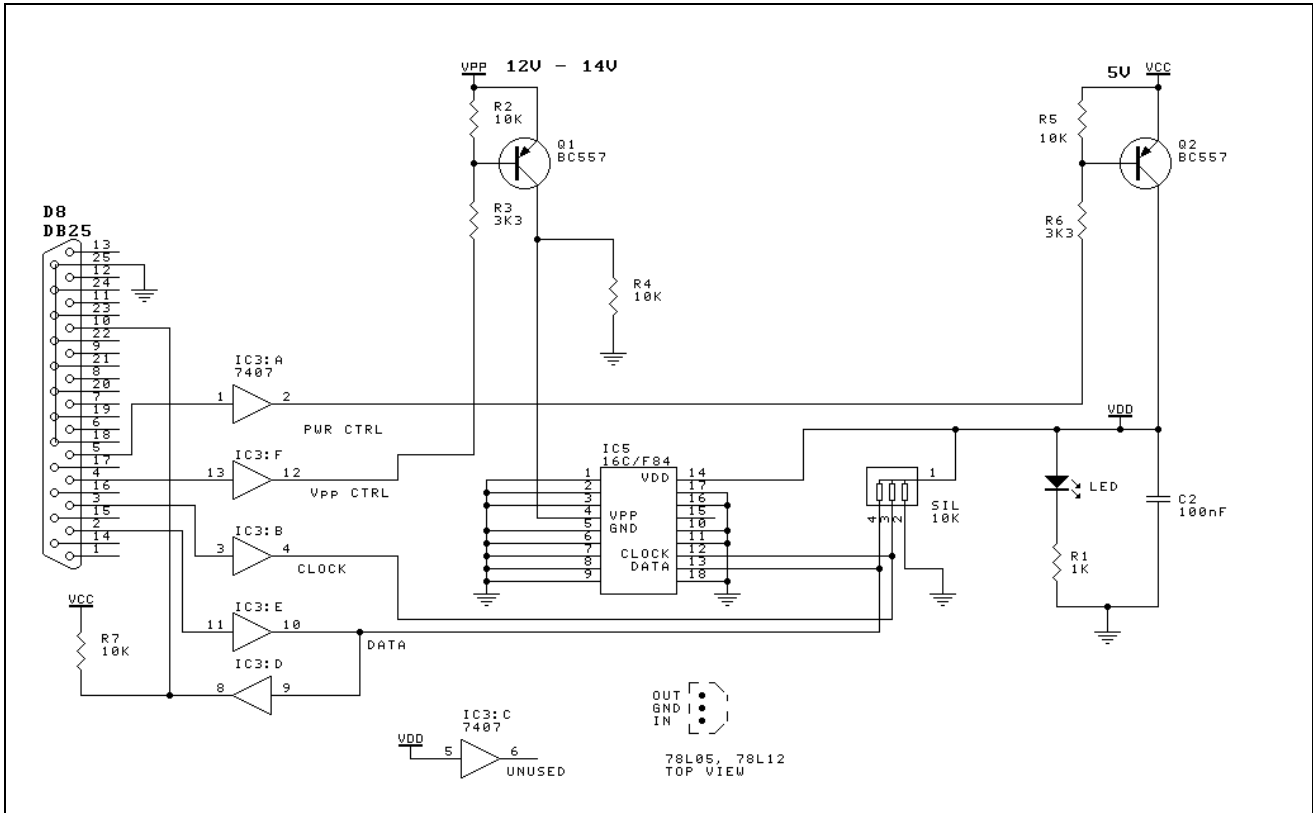

Figure 2. Basic Programmer Circuit

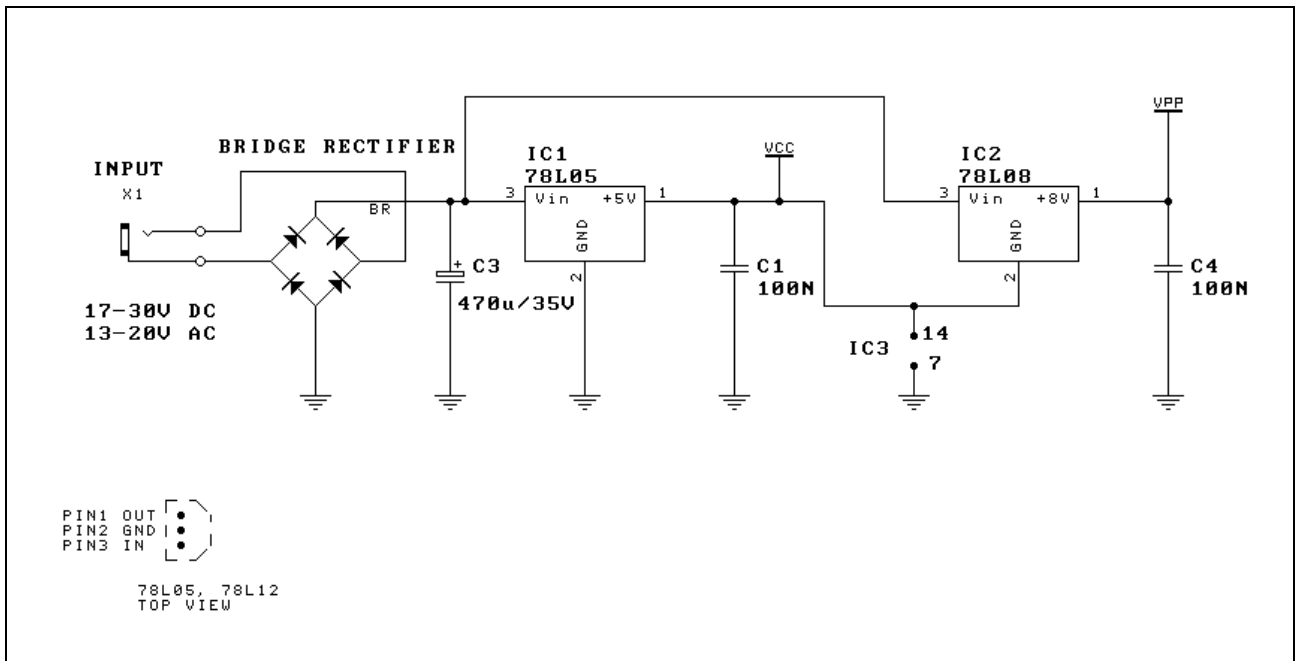

Figure 3. Power Supply