

AM RADIO KIT

MODEL AM-780K

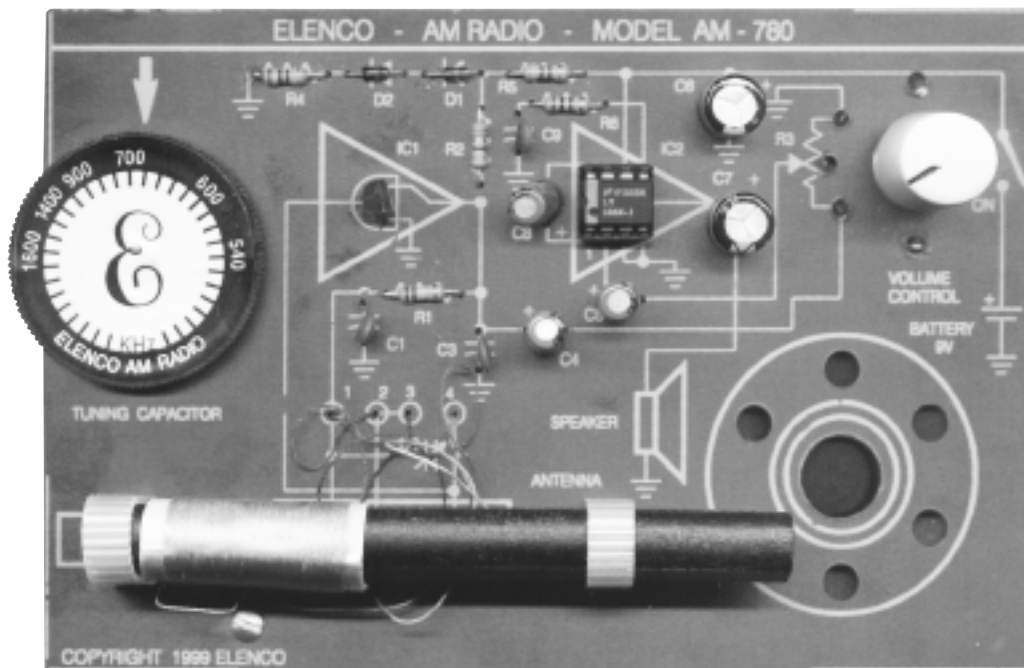

7 56619 00161 6



Assembly and Instruction Manual

PARTS LIST

If any parts are missing or damaged, see instructor or bookstore. **DO NOT** contact your place of purchase as they will not be able to help you. Contact Elenco™ Electronics (address/phone/e-mail is at the back of this manual) for additional assistance, if needed.

RESISTORS

Qty.	Symbol	Value	Color Code	Part #
□ 1	R6	10Ω 5% 1/4W	brown-black-black-gold	121000
□ 1	R4	150Ω 5% 1/4W	brown-green-brown-gold	131500
□ 1	R2	3.3kΩ 5% 1/4W	orange-orange-red-gold	143300
□ 1	R5	8.2kΩ 5% 1/4W	gray-red-red-gold	148200
□ 1	R1	100kΩ 5% 1/4W	brown-black-yellow-gold	161000
□ 1	R3	Potentiometer 50kΩ & switch w/ Nut & Washer		192522

CAPACITORS

Qty.	Symbol	Value	Description	Part #
□ 1	C2		Variable Tuning Capacitor	211677
□ 1	C1	.01μF	Discap (103)	241031
□ 2	C3, C9	.047μF	Discap (473)	244700
□ 3	C4, C5, C8	10μF	Electrolytic Radial	271045
□ 2	C6, C7	470μF	Electrolytic Radial	284743

SEMICONDUCTORS

Qty.	Symbol	Value	Description	Part #
□ 2	D1, D2	1N4148	Semiconductor Silicon Diode	314148
□ 1	IC2	LM-386	Integrated Circuit	330386
□ 1	IC1	484	Integrated Circuit	33K484

MISCELLANEOUS

Qty.	Description	Part #	Qty.	Description	Part #
□ 1	Antenna with Holders	484004	□ 1	Screw 2-56 x 5/16"	641231
□ 1	PC Board	517053	□ 3	Screw #3 x 5/32"	641310
□ 2'	Solder	551124	□ 1	Nut 2-56	644201
□ 1	Battery Holder	590096	□ 1	Socket IC 8-pin	664008
□ 1	Speaker 8Ω	590102	□ 1	Label	720421
□ 1	Knob for Potentiometer	622017	□ 1	Speaker Pad	780128
□ 1	Knob for Variable Capacitor	622030	□ 4	Wire 2"	834011

PARTS IDENTIFICATION

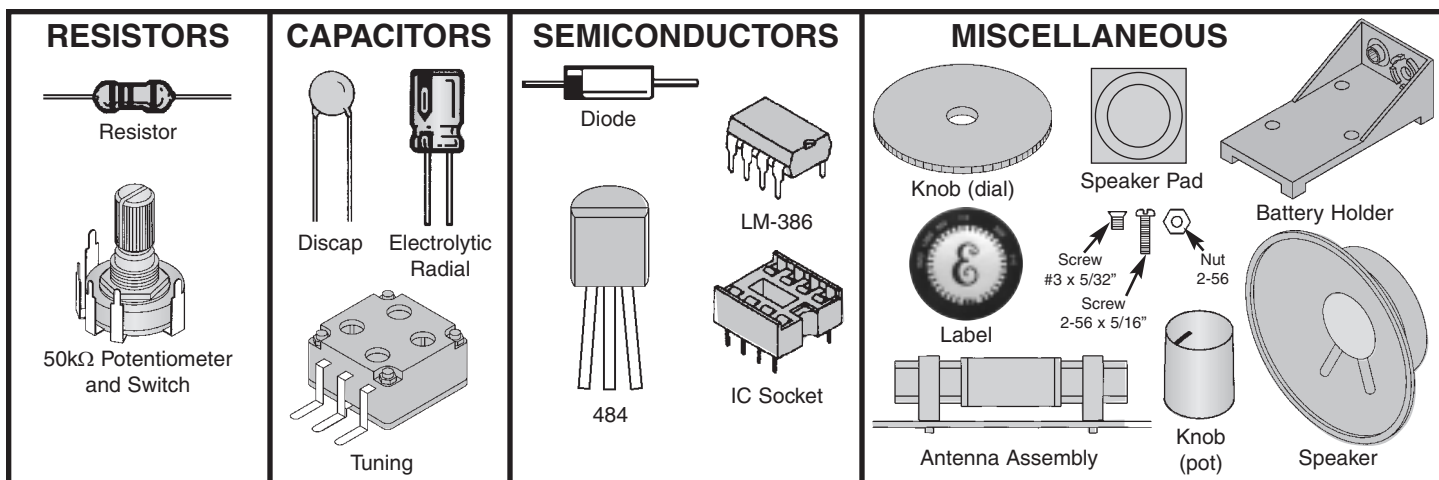

You Will Need:

- 9V Battery
- 25 or 30 watt Soldering Iron
- Small Phillips and Slotted Screwdrivers
- Long Nose Plier
- Side Cutters

IDENTIFYING RESISTOR VALUES

Use the following information as a guide in properly identifying the value of resistors.

BAND 1 1st Digit		BAND 2 2nd Digit		Multiplier		Resistance Tolerance	
Color	Digit	Color	Digit	Color	Multiplier	Color	Tolerance
Black	0	Black	0	Black	1	Silver	±10%
Brown	1	Brown	1	Brown	10	Gold	±5%
Red	2	Red	2	Red	100	Brown	±1%
Orange	3	Orange	3	Orange	1,000	Red	±2%
Yellow	4	Yellow	4	Yellow	10,000	Orange	±3%
Green	5	Green	5	Green	100,000	Green	±5%
Blue	6	Blue	6	Blue	1,000,000	Blue	±.25%
Violet	7	Violet	7	Silver	0.01	Violet	±.1%
Gray	8	Gray	8	Gold	0.1		
White	9	White	9				

BANDS

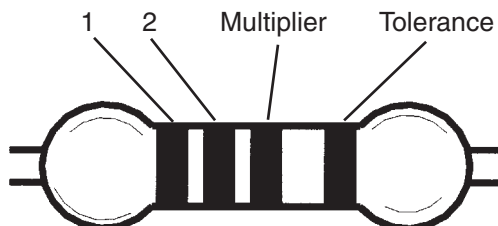

IDENTIFYING CAPACITOR VALUES

Capacitors will be identified by their capacitance value in pF (picofarads), nF (nanofarads), or μ F (microfarads). Most capacitors will have their actual value printed on them. Some capacitors may have their value printed in the following manner. The maximum operating voltage may also be printed on the capacitor.

Multiplier	For the No.	0	1	2	3	4	5	8	9
		Multiply By	1	10	100	1k	10k	100k	.01

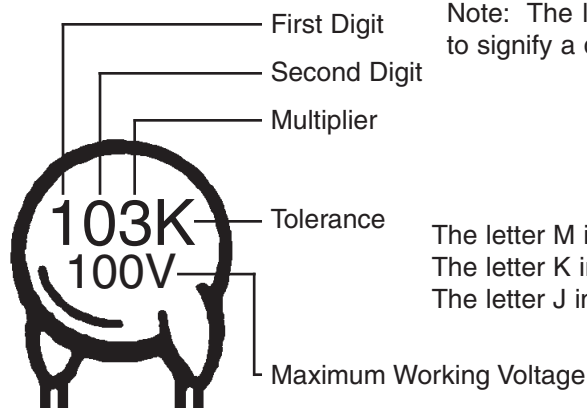

Note: The letter "R" may be used at times to signify a decimal point; as in 3R3 = 3.3

The letter M indicates a tolerance of ±20%
 The letter K indicates a tolerance of ±10%
 The letter J indicates a tolerance of ±5%

The value is $10 \times 1,000 = 10,000\text{pF}$ or $.01\mu\text{F}$ 100V

WHAT IT IS

The AM-780K is a tuned radio frequency (TRF) receiver of the standard AM (amplitude modulation) broadcast frequencies (550kHz - 1600kHz). Easy-to-build, using only two integral circuits (IC).

Assembly of your AM-780K AM Radio Kit will prove to be an exciting project and give you much satisfaction and personal achievement. Care must be given to identifying the proper components and

in good soldering habits. Above all, take your time and follow these easy step-by-step instructions. Remember, "An ounce of prevention is worth a pound of cure". Avoid making mistakes and no problems will occur.

Construction Time: About 3 Hours.

INTRODUCTION

The Model AM-780K AM Radio can be best understood by analysis of the block diagram shown in Figure 1.

The coils on the ferrite rod antenna (L1 and L2) and the variable capacitors (C2) make up a "tuned circuit" (see schematic diagram below). It is a very selective filter. The frequency is selectable over a certain range by adjusting the tuning capacitor. The selectable signal is passed into IC1 (integrated circuit 484) where it is amplified and then detected. The 484 is a monolithic integral circuit equal to a ten transistor tuned radio frequency circuit. The resistor R2 and the capacitor C3 set the automatic gain control of IC1. The 484 requires a low voltage power supply (1.1 - 1.8V). The voltage drop across diodes D1, D2, and resistor R4 is the correct supply voltage to IC1.

The output from a diode detector of the 484 is typically 40 - 60mV. This audio signal is too weak to drive a speaker directly. Capacitor C3 filters out the radio frequency component of the signal, leaving a clean audio signal.

The amount of gain control is varied by potentiometer R3, which also varies the audio level and consequently the volume. Capacitor C5 couples the audio signal from the volume control to the input of the audio amplifier. Our kit uses the standard design for the audio amplifier on the base of the integral circuit LM-386. To make the LM-386 a more versatile amplifier, two pins (1 and 8) are provided for gain control. With pins 1 and 8 open, the gain at 20, the capacitor will go up to 200. Capacitor C7 blocks the DC from the speaker while allowing the AC to pass.

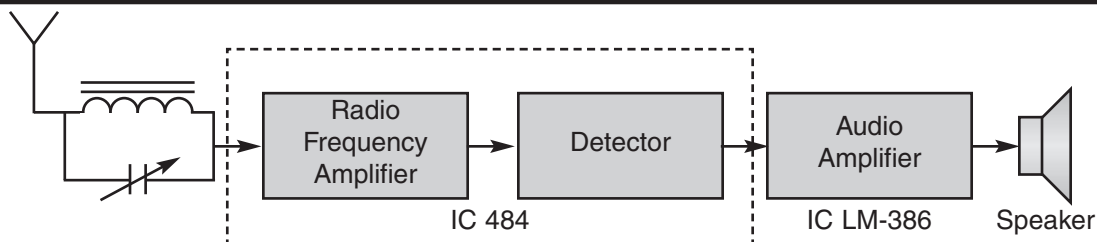
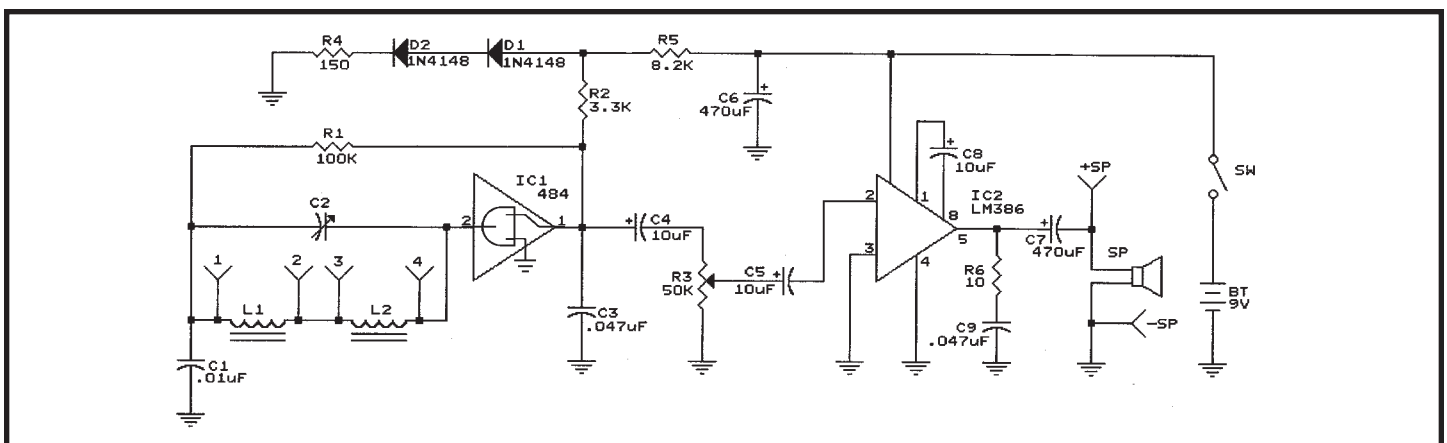

Figure 1

SCHEMATIC DIAGRAM AM-780K



CONSTRUCTION

Introduction

The most important factor in assembling your AM-780K AM Radio Kit is good soldering techniques. Using the proper soldering iron is of prime importance. A small pencil type soldering iron of 25 - 30 watts is recommended. **The tip of the iron must be kept clean at all times and well tinned.**

Safety Procedures

- Wear eye protection when soldering.
- Locate soldering iron in an area where you do not have to go around it or reach over it.
- **Do not hold solder in your mouth.** Solder contains lead and is a toxic substance. Wash your hands thoroughly after handling solder.
- Be sure that there is adequate ventilation present.

Assemble Components

In all of the following assembly steps, the components must be installed on the top side of the PC board unless otherwise indicated. The top legend shows where each component goes. The leads pass through the corresponding holes in the board and are soldered on the foil side.

Use only rosin core solder of 63/37 alloy.

DO NOT USE ACID CORE SOLDER!

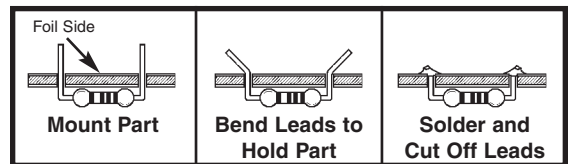

What Good Soldering Looks Like

A good solder connection should be bright, shiny, smooth, and uniformly flowed over all surfaces.

1. Solder all components from the copper foil side only. Push the soldering iron tip against both the lead and the circuit board foil.

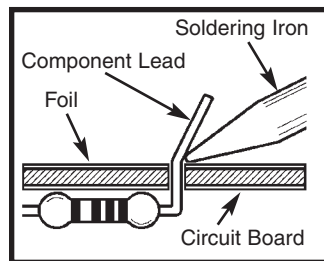

2. Apply a small amount of solder to the iron tip. This allows the heat to leave the iron and onto the foil. Immediately apply solder to the opposite side of the connection, away from the iron. Allow the heated component and the circuit foil to melt the solder.

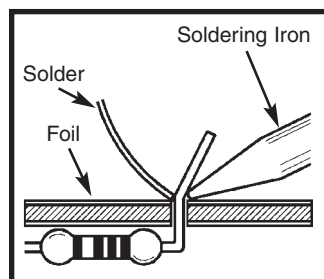

3. Allow the solder to flow around the connection. Then, remove the solder and the iron and let the connection cool. The solder should have flowed smoothly and not lump around the wire lead.

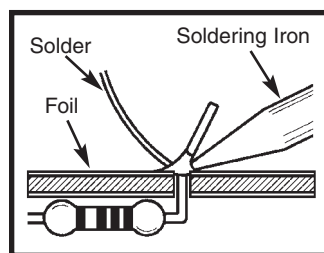

4. Here is what a good solder connection looks like.

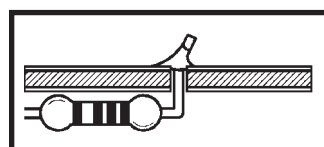

Types of Poor Soldering Connections

1. **Insufficient heat** - the solder will not flow onto the lead as shown.

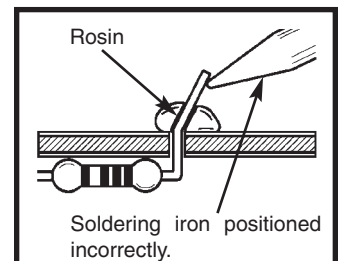

2. **Insufficient solder** - let the solder flow over the connection until it is covered. Use just enough solder to cover the connection.

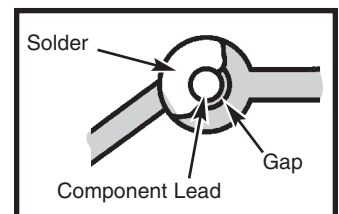

3. **Excessive solder** - could make connections that you did not intend to between adjacent foil areas or terminals.

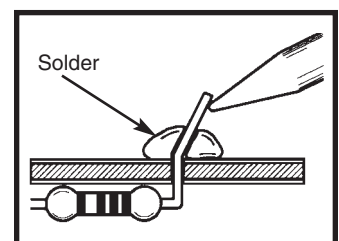

4. **Solder bridges** - occur when solder runs between circuit paths and creates a short circuit. This is usually caused by using too much solder. To correct this, simply drag your soldering iron across the solder bridge as shown.

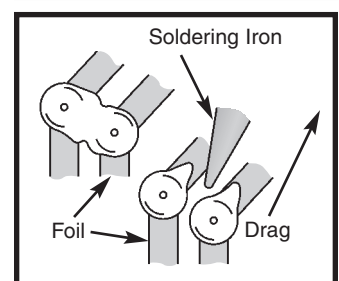

ASSEMBLE COMPONENTS TO THE PC BOARD

Place a check mark in the box provided next to each step to indicate that the step is completed.

- D1 - 1N4148 Diode
- D2 - 1N4148 Diode
(see Figure A)
- R4 - 150Ω 5% 1/4W Res.
(brown-green-brown-gold)
- R2 - 3.3kΩ 5% 1/4W Res.
(orange-orange-red-gold)
- IC1 - 484 IC
(see Figure B)
- R1 - 100kΩ 5% 1/4W Res.
(brown-black-yellow-gold)
- C1 - .01μF Discap (103)
- C3 - .047μF Discap (473)
- C5 - 10μF Electrolytic
- C4 - 10μF Electrolytic
- C8 - 10μF Electrolytic
(see Figure C)

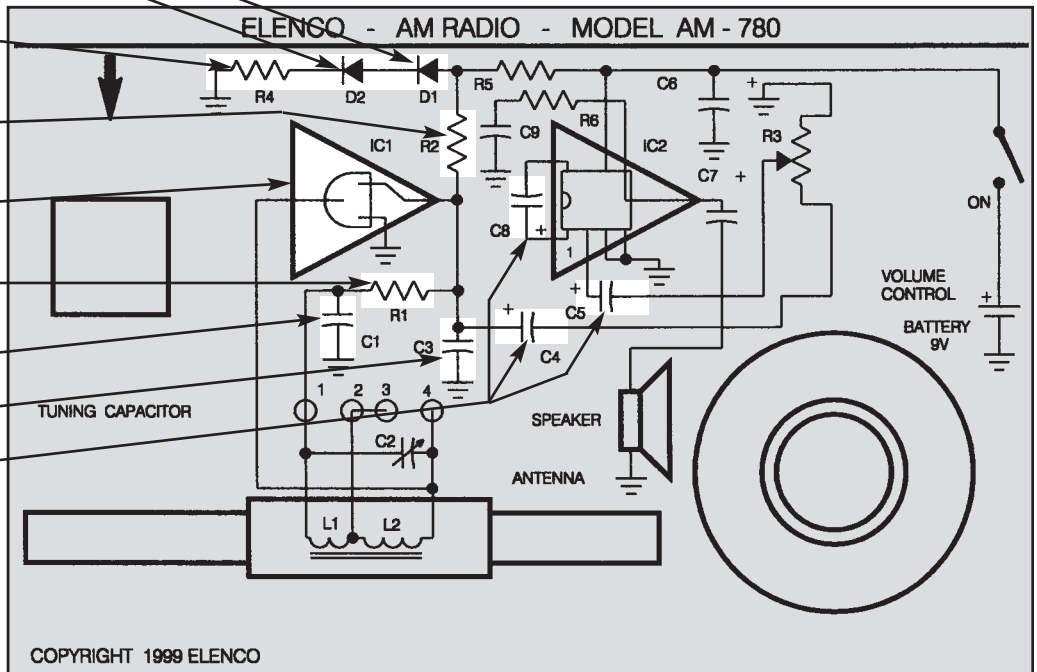

Figure A

Mount diode with the band in the same direction as marked on the PC board. Solder and cut off the excess leads.

Figure B

Mount the IC with the flat side in the same direction as marked on the PC board. Solder and cut off the excess leads.

Figure C

Polarity Mark
(-) (+)

Electrolytics have a polarity marking indicating the (-) lead. The PC board is marked to show the lead position.

Figure D

Insert the IC socket into the PC board with the notch in the direction shown on the top legend. Solder the IC socket into place. Insert the IC into the socket with the notch in the same direction as the notch on the socket.

Figure E

Step 1: If the speaker pad has center and outside pieces, then remove them. Peel the backing off of one side of the speaker pad and stick the pad onto the speaker.

Step 2: Remove the other backing from the speaker pad.

Step 3: Stick the speaker onto the solder side of the PC board.

Step 4: Solder the 2 wires from the speaker to the pads +SP and -SP.

ASSEMBLE COMPONENTS TO THE PC BOARD

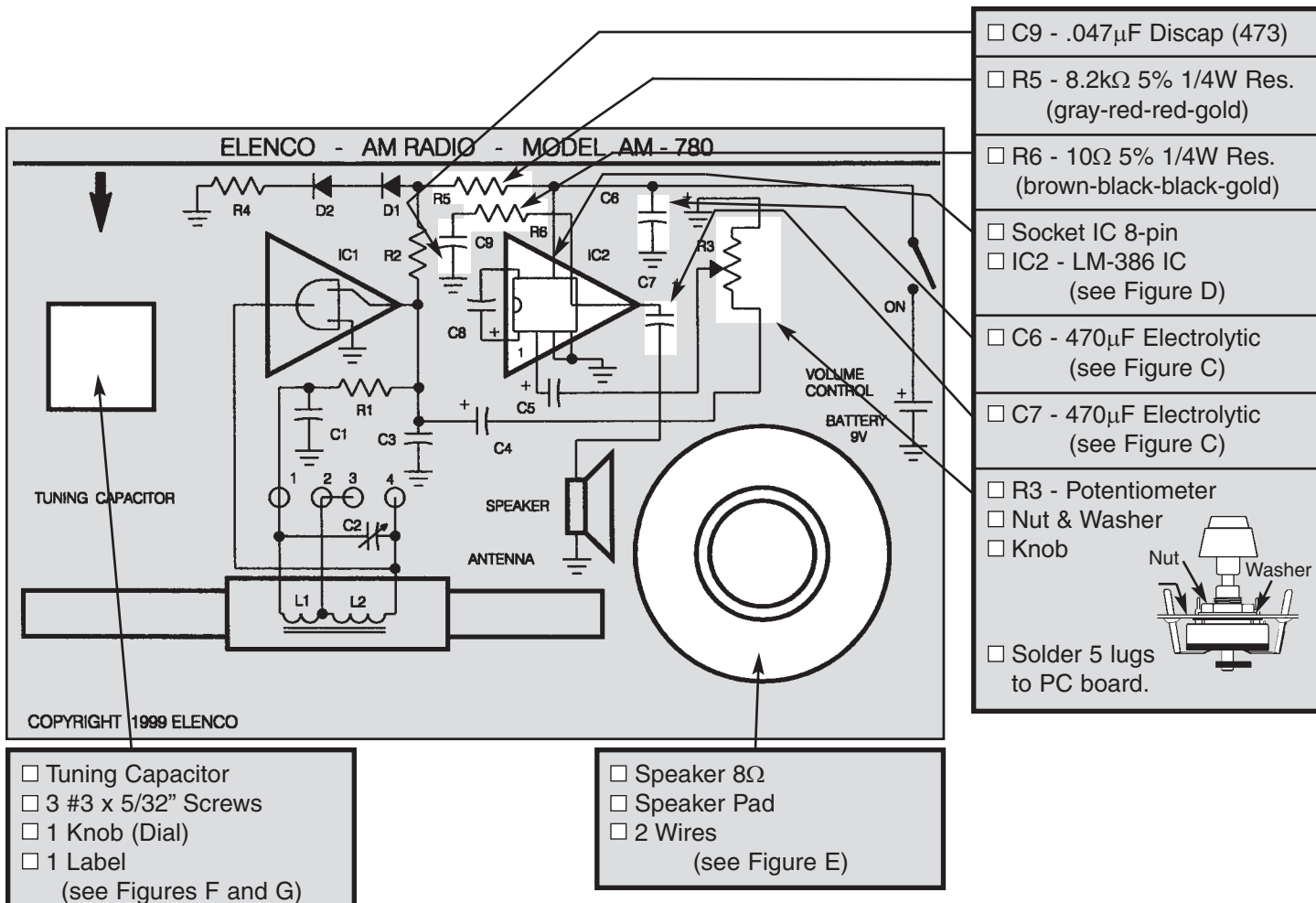

**Tuning Capacitor
Figure F**

Your kit may contain a 3 lead or a 4 lead capacitor. Bend the leads as shown. Fasten C1 into place on the top side of the PC board with two #3 x 5/32" screws. Fasten the knob to the shaft of the gang with a screw.

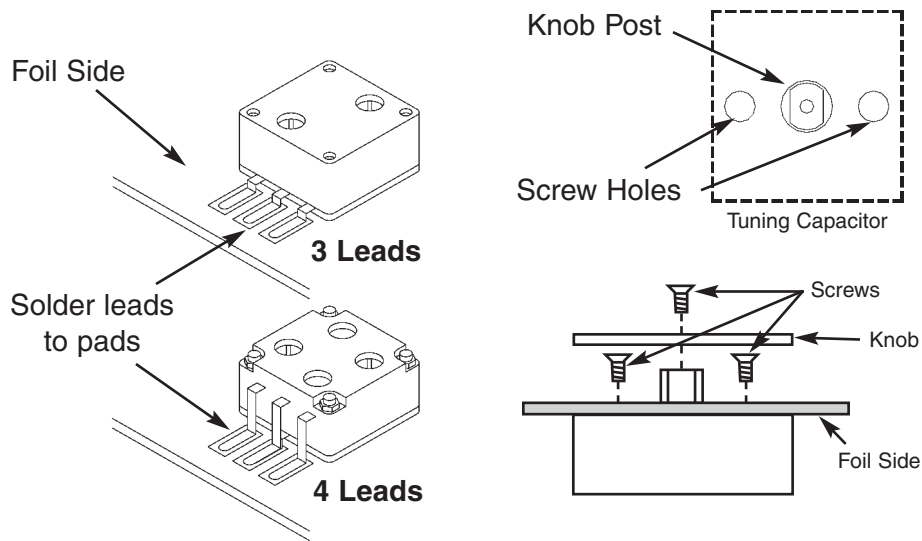
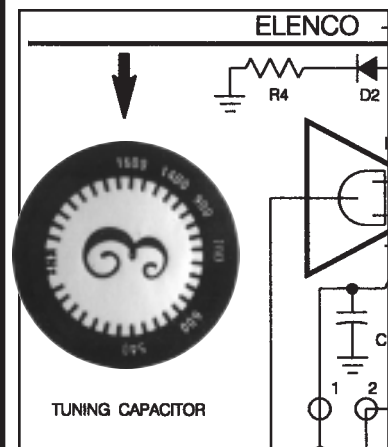

Figure G

Turn the dial fully clockwise. Remove the protective backing from the label and align the 1600 with the arrow on the PC board. **NOTE: SAVE** the protective backing from the label for it will be used on page 8.



INSTALL BATTERY HOLDER AND ANTENNA

- Bend the leads of the battery holder as shown in Figure H. Fasten the battery holder to the PC board with a 2-56 x 5/16" screw and 2-56 nut. Solder the leads to the PC board pads as shown.
- Install the antenna coil as shown in Figure I.

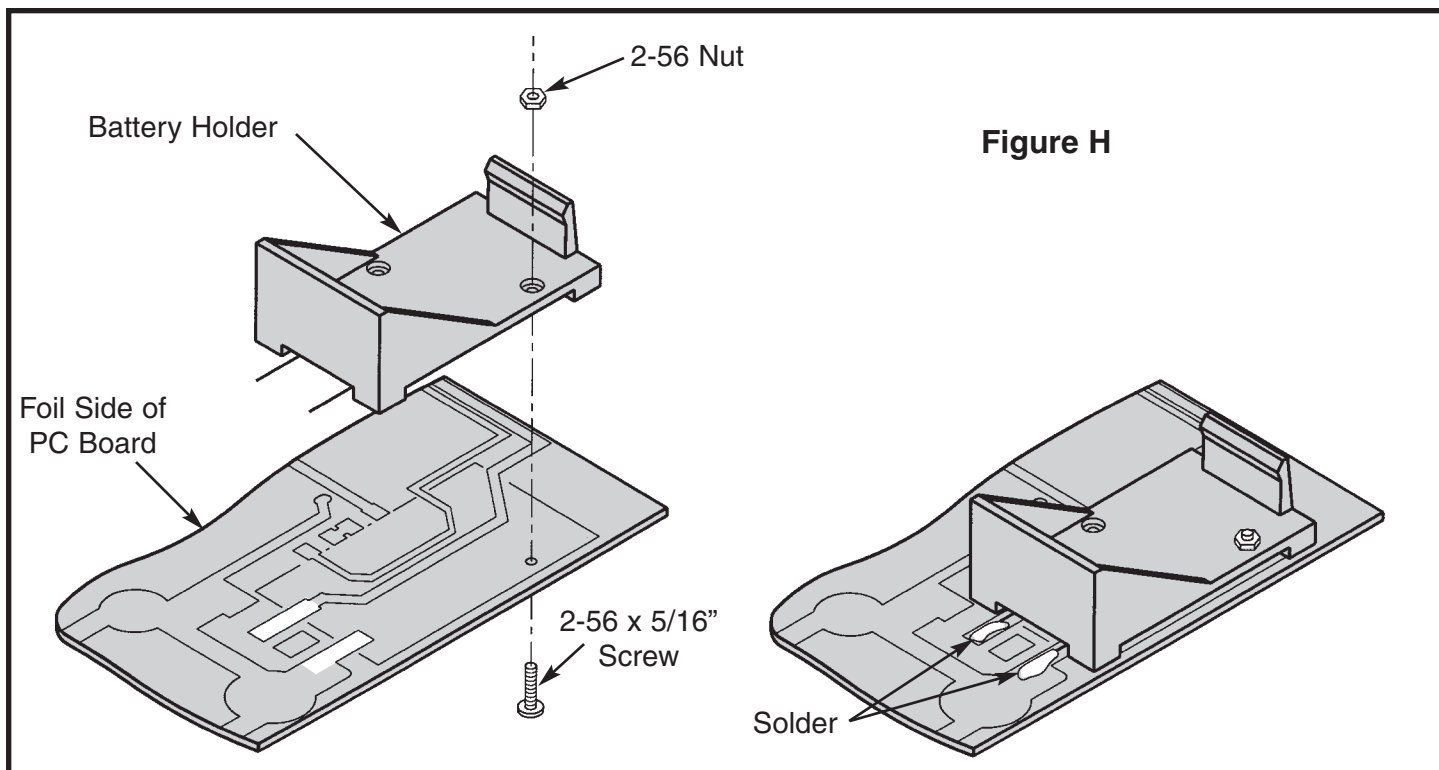

Assemble and mount the antenna to the PC board as shown below.

- Put the tab of the first holder into the right hole and twist the tab 90°.
- Put the tab of the second holder into the left hole and twist the tab 90°.
- Slide the ferrite core through the left holder.
- Slide the antenna coil through the ferrite core.
- Slide the ferrite core through the right holder.

Note: If the end of a wire from the antenna should break off, strip the insulation off the end with a hot soldering iron. Lay the wire down on a hard surface and stroke the wire with your iron. The insulation should come off very easily. **CAUTION:** The soldering iron will burn the hard surface that you are working on.

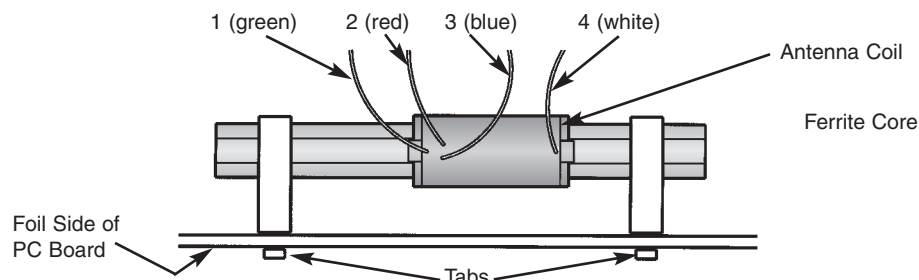

Solder the 4 colored wires to the PC board:

- Wire 1 (green) to the hole marked "1"
- Wire 2 (red) to the hole marked "2"
- Wire 3 (blue) to the hole marked "3"
- Wire 4 (white) to the hole marked "4"

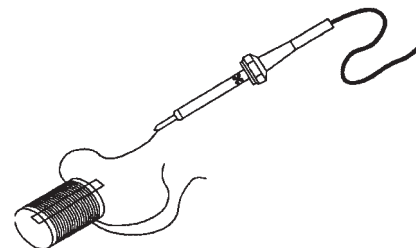

ALIGNMENT

- Using a small, slotted screwdriver, adjust the trimmer located on the back of the tuning

capacitor to minimum capacitance (as shown in Figure J).

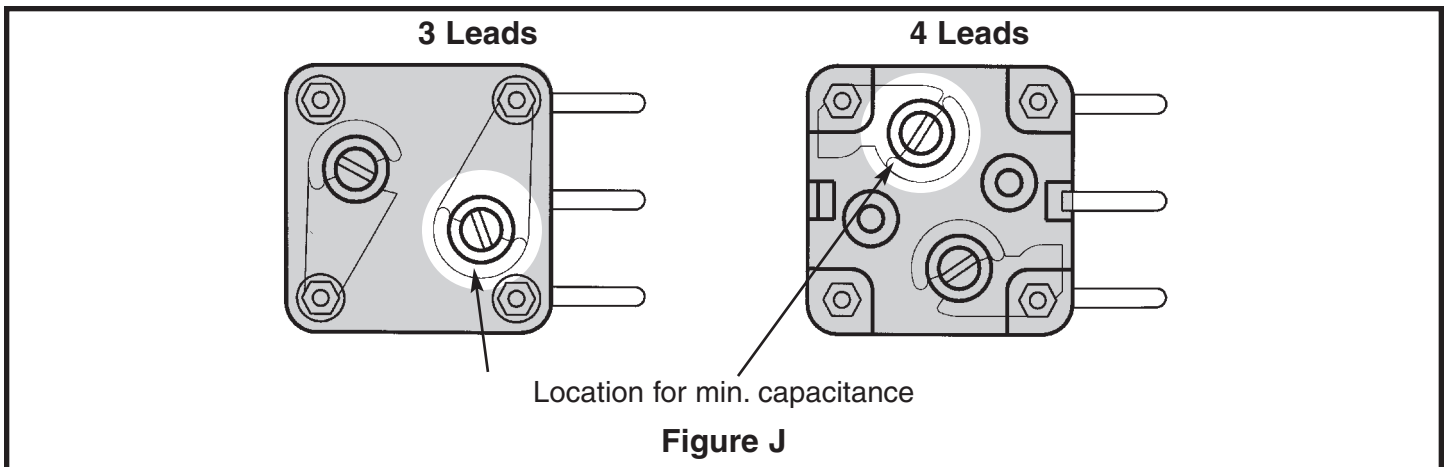

- Turn the power OFF. Put a fresh 9V battery into the battery holder and turn the power ON. Adjust the volume to a comfortable level. Tune the dial (around 1000kHz) until a weak station is heard. Carefully slide the antenna coil on its ferrite core until the station is at its loudest.

- Use the paper left over from the Radio Dial Label used in Figure G and fold it in half as shown in Figure K. Fold it in half once more as shown. Now you have a shim to hold the coil in place.
- Slide the shim, in-between the coil and the ferrite core as shown in Figure L.

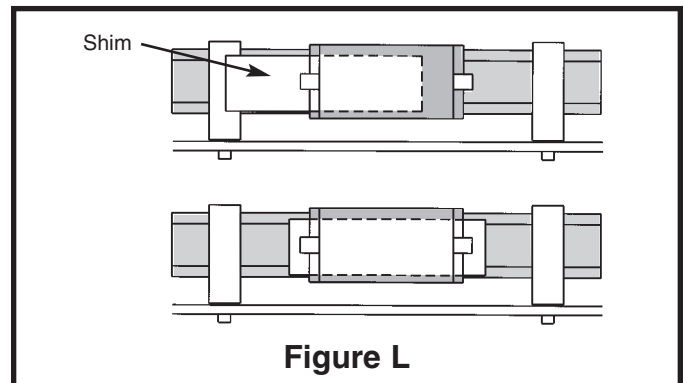
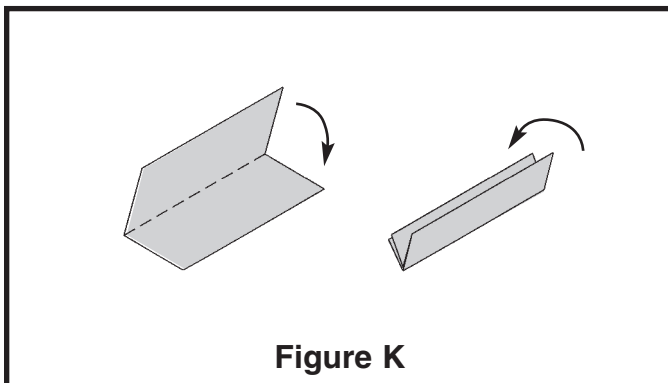

TROUBLESHOOTING

Contact Elenco™ Electronics if you have any problems. **DO NOT** contact your place of purchase as they will not be able to help you.

1. One of the most frequently occurring problems is poor solder connections.
 - a) Tug slightly on all parts to make sure that they are indeed soldered.
 - b) All solder connections should be shiny. Resolder any that are not.
 - c) Solder should flow into a smooth puddle rather than a round ball. Resolder any connection that has formed into a ball.

- d) Have any solder bridges formed? A solder bridge may occur if you accidentally touch an adjacent foil by using too much solder or by dragging the soldering iron across adjacent foils. Break the bridge with your soldering iron.

2. Use a fresh 9V battery.

3. Make sure that all of the parts are placed in their correct positions. Check if the IC, diode and lytic orientations are correct.
4. Use a 2" wire to short capacitor C2 (see Figure M). Turn the volume control up halfway:
 - a) Short by wire, the speaker terminals several times. If you don't hear tapping from the speaker, check the speaker, battery, battery holder, capacitor C6 and the switch.
 - b) Short by wire, pins 4 and 5 of IC2 several times. If you don't hear tapping from the speaker, check the wires from the PC board to the speaker and capacitor C7.
 - c) Short pins 2 and 3 of IC2 several times. If you don't hear tapping from the speaker, check IC2 and capacitor C8.
 - d) Short pins 1 and 3 of IC1 several times. If you don't hear tapping from the speaker, check capacitors C3, C4 and C5 and resistor R3.
 - e) Short pins 2 and 3 of IC1 several times. If you don't hear tapping from the speaker, check IC1, R1, R2, R4, R5, D1, D2 and C1. Turn OFF power. Remove the short wire from C2.
 - f) Check the antenna coils L1 and L2 and capacitor C2. If you have an ohmmeter, measure the resistance on the pads of capacitor C2 (see Figure N). The resistance should be approximately 11Ω . If the resistance is infinity, check the antenna coils L1 and L2. If the resistance is around "0", check capacitor C2.

5. The DC voltage readings below should be used for test conditions: Volume set to minimum, battery voltage = 9V; all voltages are referenced to the circuit common. Voltage readings can vary $\pm 10\%$.

Note: C2 should be shorted.

(IC2) 1 - 1.32V	(IC1) 1 (output) - .830V
2 - 8mV	2 (input) - .810V
3 - 0	3 (GND) - 0
4 - 0	
5 - 4.35V	
6 - 9V	Anode of D1 - 1.33V
7 - 4.55V	Anode of D2 - .720
8 - 1.33V	

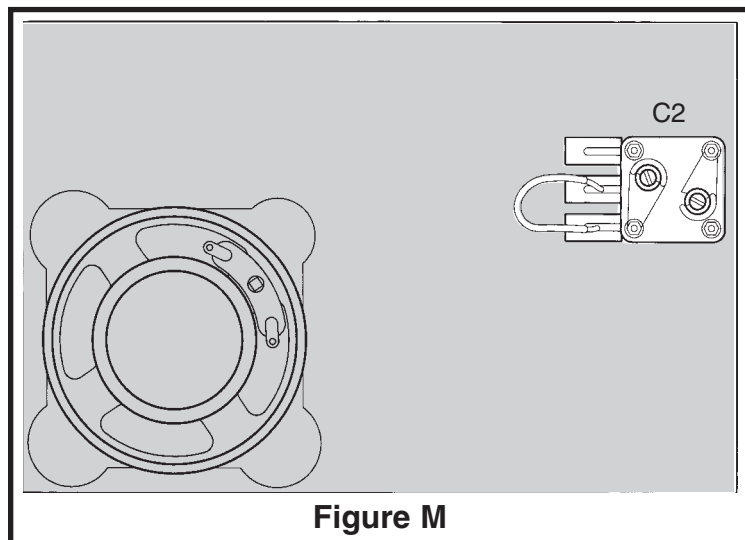

Figure M

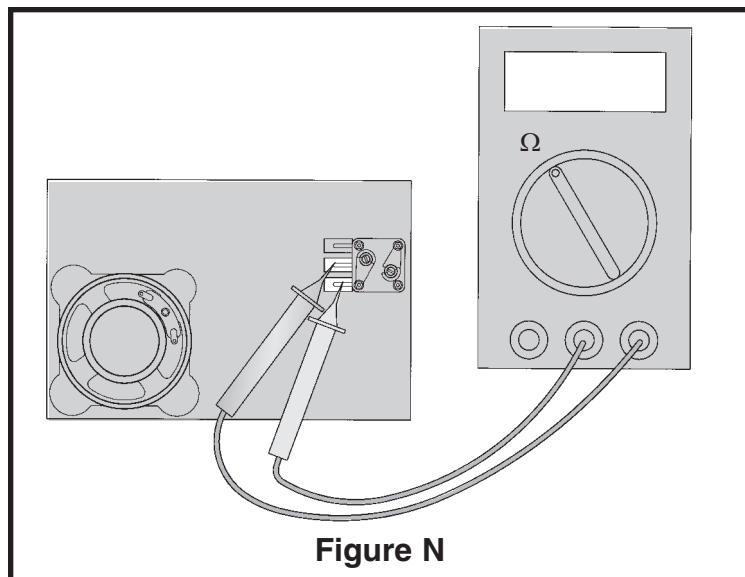

Figure N

GLOSSARY

AGC	Automatic Gain Control.	FM	Frequency Modulation.
AF	Audio Frequency	Frequency	Wave or pulse repetition rate.
AM	Amplitude Modulation	Gain	Signal multiplication.
Amplifier	Converts input signal to output.	IC	Integrated Circuit.
Anode	The positive terminal of a diode.	PC Board	Printed Circuit Board.
Antenna	Any device that either radiates a signal or pulls in a signal.	Potentiometer	Three-terminal variable resistor, volume control.
Baffle	Used to ensure positive airflow.	Power Supply	An electronic circuit that produces the necessary power for another circuit.
Capacitor	An electronic component that has ability to store a charge and block DC current.	Resistor	An electronic component that obstructs (resists) the flow of electricity.
Cathode	The negative terminal of a diode.	Speaker	An electronic device that turn electric impulses into sound.
Coil	A component with inductive reactance.	Transistor	A semiconductor component that can be used to amplify signals, or as electronic switches.
Current	Electrical flow.		
Diode	An electronic component that changes alternating current to direct current.		

